

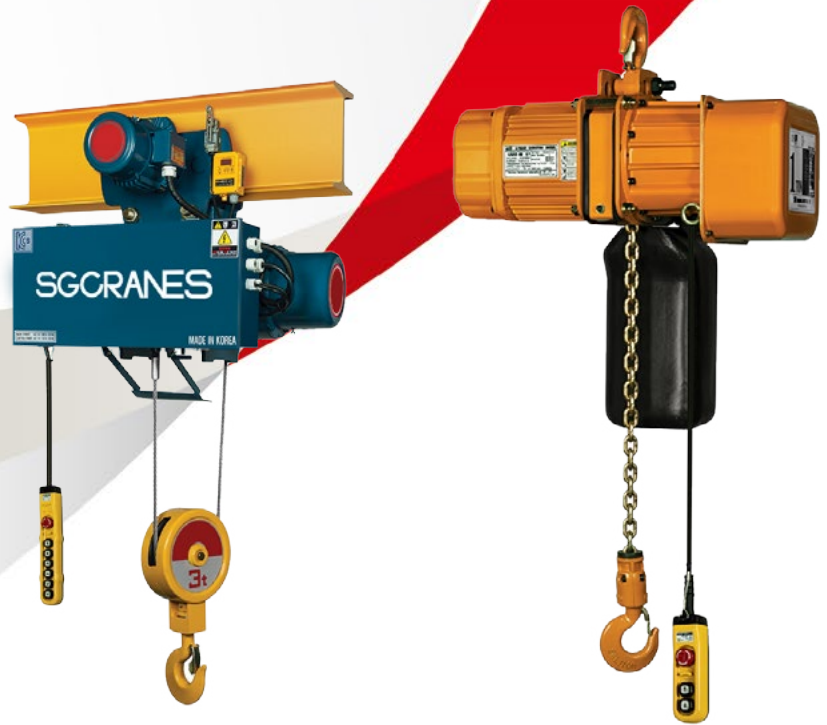

# Electric Hoist



Wire Rope Hoist

Chain Hoist



**Contents**

**Hoist**

Wire Rope Hoist 4  
 Explosion Proof Wire Hoist 10  
 Chain Hoist 29  
 Air Hoist 34  
 Air Balancer 38  
 Zero Balancer 39  
 Winch (Air, Electric) 40  
 Remote Control & Load Cell 41

**Production Process** 42

SGCRANES has been designing, manufacturing and selling industrial hoists, cranes and crane parts for over 30 years since 1989.

Today, we have developed a comprehensive engineering company supplying hoists and cranes to semiconductor factories, chemical plants, steel factories, automobile factories and shipyards in more than 30 countries around the world.

With 30 years of experience and accomplishments, we will continue to supply our customers with the fastest, best products at realistic prices with the goal of 100 years in the future.

Please visit our HOME PAGE [www.sgcranes.com](http://www.sgcranes.com) for your required equipment and we will respond immediately.

Thank you.



**Sung Goo Kim / CEO**  
**SGCRANES**

**Wire Rope Hoist**

**Selection Criteria**

You can use WIRE HOIST for a long time without any trouble if you select it properly according SGCRANES Wire Hoists are allocated to mechanism groups in accordance with the following regulations. Under the allowance of the following mechanism groups, the hoist should be operated and should not exceed the nominal values. On each identification plate, the following is indicated.

Motor trolley mounted series : FEM 9.511 (Hoist / Trolley + FEM 2m 1Am 40 / 25% ED) Starting frequency = 240 time / Hr.

FEM Mechansim Group 9.511  
 (Rules for Design of Serial Lifting Equipment : Classification of Mechanism)

Mechanism group	1Bm	1Am	2m	3m	4m	5m
Load group	Average operating period per day (h)					
Ligh k < 0.50	<2	2-4	4-8	8-16	>16	
Medium 0.50 < k < 0.63	<1	1-2	2-4	4-8	8-16	>16
Heavy 0.30 < k < 0.80	<0.5	0.5-1	1-2	2-4	4-8	8-16
Very Heavy 0.80 < k < 1.00	<0.25	<0.5	0.5-1	1-2	2-4	4-8

**Specifications**

Hoist	Regular type				Low-head type	Double type
	Suspension	Hoist with	Hoist with	Hoist with	Hoist with	Hoist with
Specifications	Hoist	hand-push trolley	geared trolley	motor-driven trolley	motor-driven trolley	motor-driven trolley
Power supply	220/380/415/440/460/480 ~50/60Hz x 3 phase					
Ambient temperature	-10°C ~ 40°C					
Construction	Weather and dust proof					
Coating color	Munsell No. for the hoist body : 10B3/5, for the hook : 8.1YR7.6/15.2					

## (Regular Type Hoist with Motor Driven Trolley)

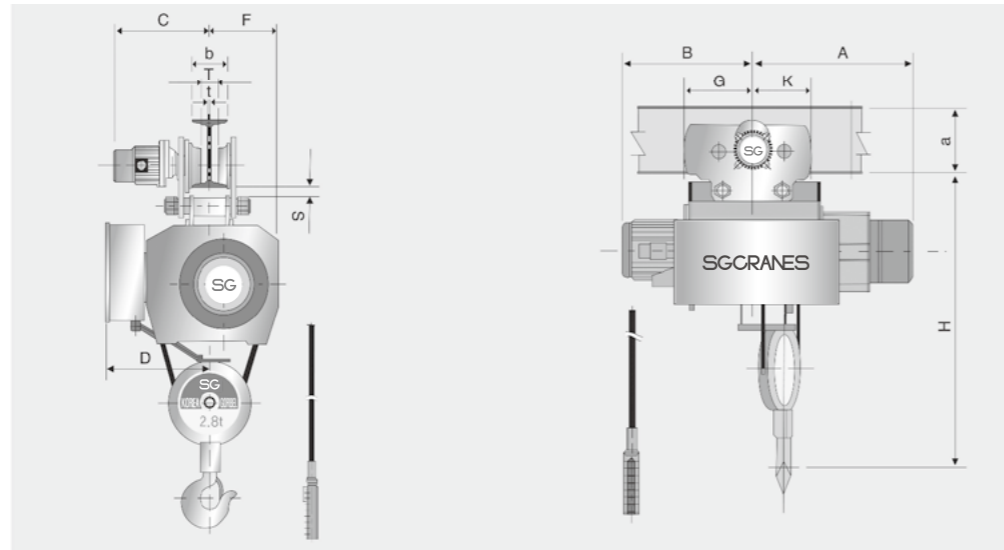

## (Regular Type Hoist with Motor Driven Trolley)

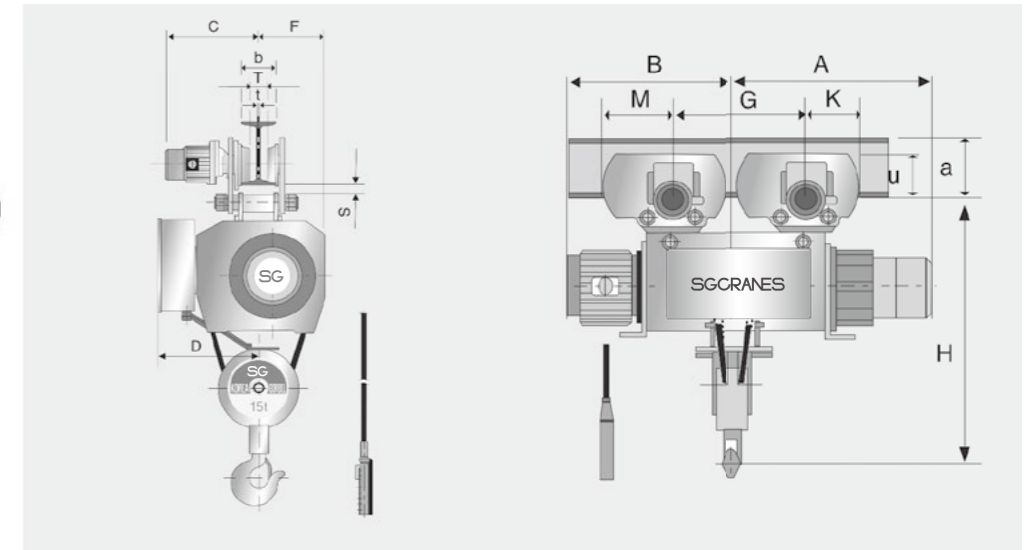

Table

Model		SN 0.5-M	SN 1-M	SN 2-M	SN 2.8-M	SN 3-M	SN 5-M	
Capacity (ton)		1/2	1	2	2.8	3	5	
Type	Hoisting Speed	High-High	SN 0.5-H6(1.2)-MH	SN 1-H6(1.2)-MH	SN 2-H6(1.2)-MH	SN 2.8-H6(1.2)-MH	SN 3-H6(1.2)-MH	SN 5-H6(1.2)-MH
		High-Low	SN 0.5-H6(1.2)-ML	SN 1-H6(1.2)-ML	SN 2-H6(1.2)-ML	SN 2.8-H6(1.2)-ML	SN 3-H6(1.2)-ML	SN 5-H6(1.2)-ML
Traversing	Hoisting Speed	High-High	SN 0.5-L6(1.2)-MH	SN 1-L6(1.2)-MH	SN 2-L6(1.2)-MH	SN 2.8-L6(1.2)-MH	SN 3-L6(1.2)-MH	SN 5-L6(1.2)-MH
		High-Low	SN 0.5-L6(1.2)-ML	SN 1-L6(1.2)-ML	SN 2-L6(1.2)-ML	SN 2.8-L6(1.2)-ML	SN 3-L6(1.2)-ML	SN 5-L6(1.2)-ML
Hoist	Max. lift(m)		6(1.2)					
	Hoisting Speed (m/min)	High Speed 50/60(Hz)	10/12	10/12	8.4/10	7.5/9	7.5/9	4.7/5.6
		Low Speed 50/60(Hz)	5/6	5/6	4.2/5	3.7/4.5	3.7/4.5	3.5/4.2
	Hoisting Motor (Kw x P)	High Speed	1.2 x 4	2.4 x 4	3.7 x 4	4.8 x 4	5.5 x 4	5.5 x 6
Low Speed		0.6 x 8	1.2 x 8	1.8 x 8	2.4 x 8	2.8 x 8	4.2 x 8	
Wire Rope	Construction		6 x 37					
	Die(mm) x No. of Ropes		6 x 2	8 x 2	10 x 2	12.5 x 2	12.5 x 2	16 x 2
Traversing	Brake		DC Magnet Disc Brake					
	Traversing Speed (m/min)	High Speed 50/60(Hz)	20/24					
		Low Speed 50/60(Hz)	13/16					
	Traversing Motor (Kw x P)	High Speed	0.4 x 4	0.4 x 4	0.75 x 4	0.75 x 4	0.75 x 4	0.75 x 4
Low Speed		0.2 x 6	0.2 x 6	0.5 x 6	0.5 x 6	0.5 x 6	0.5 x 6	
Brake		DC Magnet Disc Brake						
Dimensions (approx)(mm)	H	705	815	980	1115	1115	1325	
	A	370(465)	405(505)	465(565)	520(620)	520(620)	605(705)	
	B	355(450)	380(480)	410(510)	440(540)	440(540)	500(585)	
	D	255	275	310	365	380	415	
	G	275	255	260	260	260	275	
	K	200	200	225	225	225	275	
I-Beam and Spacing (mm)	a x b x c	C S R U V	C S R U V	C S R U V	C S R U V	C S R U V	C S R U V	
	200 x 100 x 7	385 150 38 46 144	385 170 38 46 144	- - - - -	- - - - -	- - - - -	- - - - -	
	250 x 125 x 7.5	395 150 30 71 153	395 170 30 71 153	445 205 24 71 182	445 210 23 71 182	445 210 23 71 182	455 250 39 86 224	
	300 x 150 x 10	410 150 28 96 155	410 170 28 96 155	460 205 24 96 182	460 210 23 96 182	460 210 23 96 182	465 250 37 86 224	
	450 x 175 x 13	- - - - -	- - - - -	- - - - -	- - - - -	- - - - -	480 250 34 111 228	
Min. Radius of Curvature(m)		1.5	1.5	1.8	1.8	1.8	2.3	
Weight (approx) (kg)		147(167)	190(218)	278(314)	374(418)	374(418)	577(642)	

Table

Model		SN 7.5-M	SN 10-M	SN 15-M	SN 20-M	
Capacity (ton)		7.5	10	15	20	
Type	Hoisting Speed	High-High	SN 7.5-H12-MH	SN 10-H12-MH	SN 15-H12-MH	SN 20-H12-MH
		High-Low	SN 7.5-H12-ML	SN 10-H12-ML	SN 15-H12-ML	SN 20-H12-ML
Traversing	Hoisting Speed	High-High	SN 7.5-L12-MH	SN 10-L12-MH	SN 15-L12-MH	SN 20-L12-MH
		High-Low	SN 7.5-L12-ML	SN 10-L12-ML	SN 15-L12-ML	SN 20-L12-ML
Hoist	Max. lift(m)		12			
	Hoisting Speed (m/min)	High Speed 50/60(Hz)	3.1/3.8	3.7/4.5	3.7/4.5	3.5/4.2
		Low Speed 50/60(Hz)	2.3/2.8	2.5/3	2.5/3	2.8/2.8
	Hoisting Motor (Kw x P)	High Speed	5.5 x 6	9 x 8	13 x 8	17 x 8
Low Speed		4.2 x 8	6 x 12	8.5 x 12	11.5 x 12	
Wire Rope	Construction		6 x 37			
	Die(mm) x No. of Ropes		14 x 4	6 x 4	20 x 4	22.4 x 4
Brake		DC Magnet Disc Brake				
Traversing	Traversing Speed (m/min)	High Speed 50/60(Hz)	12.5/15			
		Low Speed 50/60(Hz)	8.3/10			
	Traversing Motor (Kw x P)	High Speed	0.75 x 4	0.75 x 4	1.5 x 4	1.5 x 4
		Low Speed	0.5 x 6	0.5 x 6	1 x 6	1 x 6
Brake		DC Magnet Disc Brake				
Dimensions (approx)(mm)	H	1460	1520	1875	2115	
	A	925	975	1075	1165	
	B	835	955	1005	1220	
	D	480	510	620	640	
	G	800	800	800	850	
	K	276	276	300	300	
I-Beam and Spacing (mm)	a x b x c	C S R U V	C S R U V	C S R U V	C S R U V	
	200 x 100 x 7	500 300 35 68 224	485 330 35 68 224	- - - - -	- - - - -	
	250 x 125 x 7.5	510 300 30 93 228	490 330 30 39 228	580 370 32 77 248	580 400 32 77 248	
	300 x 150 x 10	520 300 25 118 252	496 330 25 118 252	590 370 32 92 248	590 370 32 92 248	
	Min. Radius of Curvature(m)		For Straight Rails Only			
Weight (approx) (kg)		910	1210	2030	2430	

## (Double Rail Type Hoist with Motor Driven Trolley)

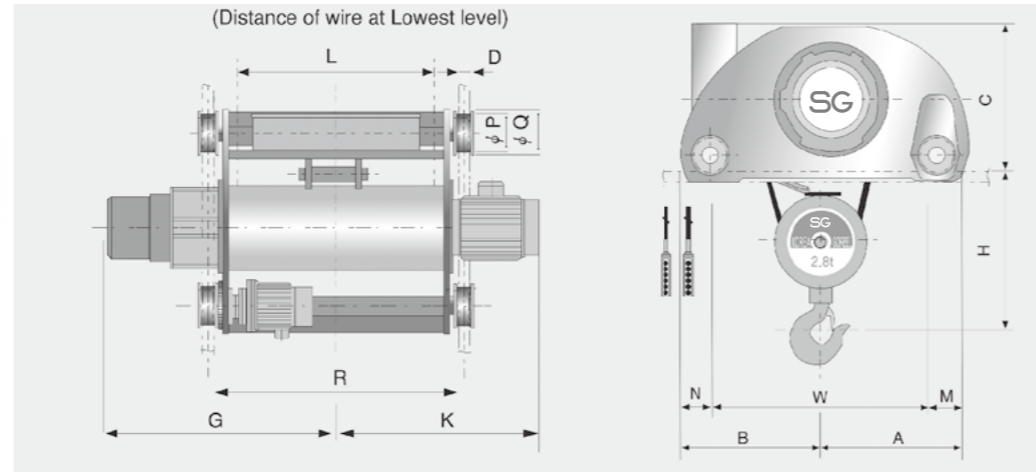

Table

Model		SD 2-M	SD 2.8-M	SD 3-M	SD 5-M	
Capacity (ton)		2	2.8	3	5	
Type	Hoisting Speed	High-High	SD 2-H12-MH	SD 3-H12-MH	SD 5-H12-MH	
		High-Low	SD 2-H12-ML	SD 3-H12-ML	SD 5-H12-ML	
Type	Traversing	High-High	SD 2-L12-MH	SD 3-L12-MH	SD 5-L12-MH	
		High-Low	SD 2-L12-ML	SD 3-L12-ML	SD 5-L12-ML	
Hoist	Max. lift(m)	12	12(14.5)	12(14.5)	(8.5)12	
	Hoisting Speed (m/min)	High Speed 50/60(Hz)	8.4/10	7.5/9	7.5/9	4.7/5.6
		Low Speed 50/60(Hz)	4.2/5	3.7/4.5	3.7/4.5	3.5/4.2
	Hoisting Motor (Kw x P)	High Speed	3.7 x 4	4.8 x 4	5.5 x 4	5.5 x 6
		Low Speed	1.8 x 8	2.4 x 8	2.8 x 8	4.2 x 8
Wire Rope	Construction	6 x 37				
	Die(mm) x No. of Ropes	8 x 4	9 x 4	9 x 4	12.5 x 4	
Brake		DC Magnet Disc Brake				
Traversing	Traversing Speed (m/min)	High Speed 50/60(Hz)	20/24			
		Low Speed 50/60(Hz)	13/16			
	Traversing Motor (Kw x P)	High Speed	0.75 x 4	0.75 x 4	0.75 x 4	0.75 x 4
Low Speed		0.5 x 6	0.5 x 6	0.5 x 6	0.5 x 6	
Brake		DC Magnet Disc Brake				
Dimensions (approx)(mm)	H	415	420	420	510	
	R	950	950(1150)	950(1150)	950(1150)	
	A	465	465	510		
	B	390	390	390	470	
	C	500	500	600	650	
	G	740	785	785	935	
	K	690	705	705	830	
	W	650	650	650	760	
	D	47	47	47	47	
	L	680	690	690	890	
	M	115	115	115	125	
N	90	90	90	110		
P	140	140	140	165		
Q	170	170	170	190		
Min. Radius of Curvature(m)		450	550	550	850	
Weight (approx) (kg)		15	15	15	15	

## (Double Rail Type Hoist with Motor Driven Trolley)

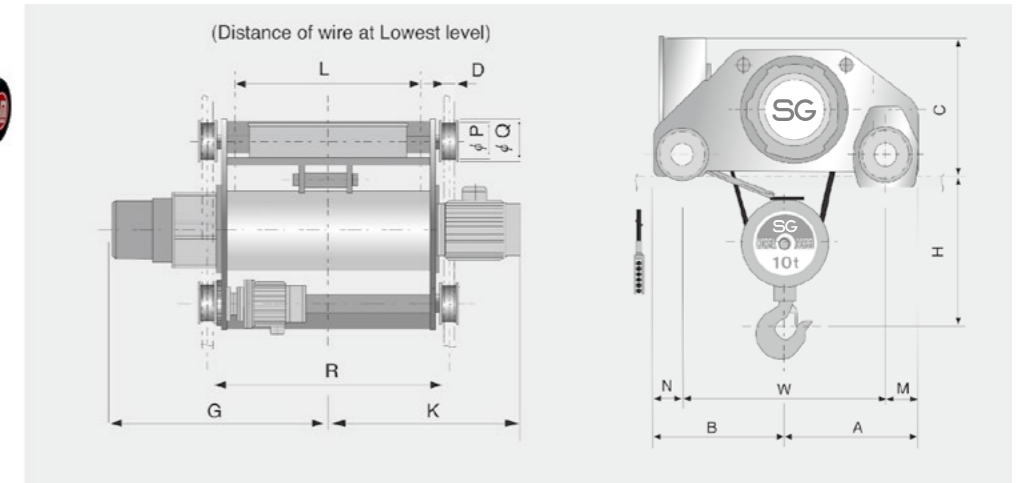

Table

Model		SD 7.5-M	SD 10-M	SD 15-M	SD 20-M	SD 30-M	
Capacity (ton)		7.5	10	15	20	30	
Type	Hoisting Speed	High-High	SD 7.5-H12-MH	SD 10-H12-MH	SD 15-H12-MH	SD 20-H12-MH	
		High-Low	SD 7.5-H12-ML	SD 10-H12-ML	SD 15-H12-ML	SD 20-H12-ML	
Type	Traversing	High-High	SD 7.5-L12-MH	SD 10-L12-MH	SD 15-L12-MH	SD 20-L12-MH	
		High-Low	SD 7.5-L12-ML	SD 10-L12-ML	SD 15-L12-ML	SD 20-L12-ML	
Hoist	Max. lift(m)	12					
	Hoisting Speed (m/min)	High Speed 50/60(Hz)	3.1/3.8	3.7/4.5	3.5/4.5	3.5/4.2	2.3/2.8
		Low Speed 50/60(Hz)	2/2.8	2.5/3	2.5/3	2.5/2.8	1.5/1.8
	Hoisting Motor (Kw x P)	High Speed	5.5 x 6	9 x 8	13 x 8	17 x 8	17 x 8
		Low Speed	4.2 x 8	6 x 12	8.5 x 12	11.5 x 12	11.5 x 12
Wire Rope	Construction	6 x 37					
	Die(mm) x No. of Ropes	14 x 4	16 x 4	20 x 4	22.4 x 4	22.4 x 6	
Brake		DC Magnet Disc Brake					
Traversing	Traversing Speed (m/min)	High Speed 50/60(Hz)	12.5/15				
		Low Speed 50/60(Hz)	8.3/10	8.3/10	8.3/10	13/10	13/10
	Traversing Motor (Kw x P)	High Speed	0.75 x 4	0.75 x 4	1.5 x 4	1.5 x 4	1.5 x 4 (2units)
Low Speed		0.5 x 6	0.5 x 6	1 x 6	1 x 6	1 x 6 (2units)	
Brake		DC Magnet Disc Brake					
Dimensions (approx)(mm)	H	730	775	995	1175	1480	
	R	1150	950(1150)	1200	1300	1800	
	A	525	565	625	670	940	
	B	480	510	555	610	940	
	C	645	695	860	900	980	
	G	925	975	1075	1165	1425	
	K	835	955	1005	1220	1480	
	W	800	865	920	1000	1540	
	D	58	58	58	58	70	
	L	852	851	872	934	1418	
	M	120	120	130	140	180	
N	95	100	130	140	160		
P	165	165	180	220	250		
Q	195	195	210	250	280		
Min. Radius of Curvature(m)		900	1200	1820	2300	3450	
Weight (approx) (kg)		15	15	22	22	30	

## (Double Rail Type Hoist with Motor Driven Trolley)

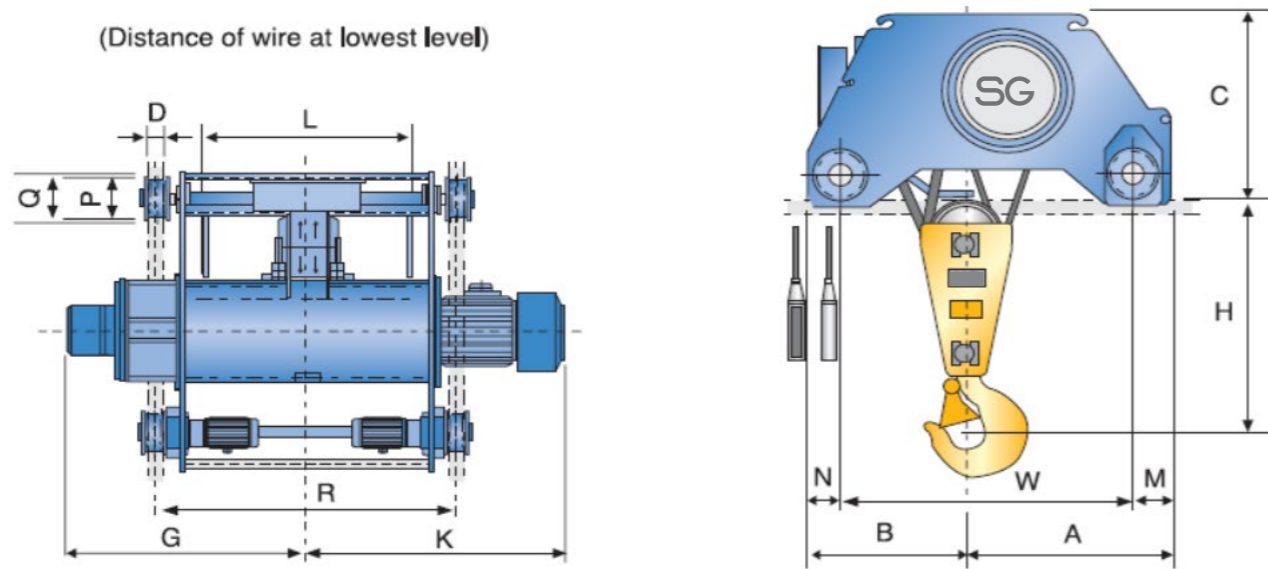

Table

Model		SD 35-M	SD 40-M	SD 50-M	SD 60-M	SD 70-M	
Capacity (ton)		35	40	50	60	70	
Traversing	High-High	SD 35-H12-MH	SD 40-H12-MH	SD 50-H12-MH	SD 60-H12-MH	SD 70-H12-MH	
	High-Low	SD 35-H12-ML	SD 40-H12-ML	SD 50-H12-ML	SD 60-H12-ML	SD 70-H12-ML	
Hoist	Max. lift(m)	12					
	Hoisting Speed (m/min)	High Speed 50/60(Hz)	4/4.8	3.5/4.2	2.7/3.2	2/2.4	
	Hoisting Motor (Kw x P)	High Speed	33 X 6				
	Wire Rope	Construction	6 X Fi(25)				
Die(mm) x No. of Ropes		28 X 4	28 X 4	28 X 6	28 X 8	28 X 8	
Traversing	Brake	DC Magnet Disc Brake					
		High Speed 50/60(Hz)	12.5/15				
	Traversing Speed (m/min)	Low Speed 50/60(Hz)	8.3/10				
		High Speed	2.2 X 4	2.2 X 4	2.2 X 4 (2units)	2.2 X 4 (2units)	3.7 X 4 (2units)
Traversing Motor (Kw x P)	Low Speed	1.5 X 6	1.5 X 6	1.5 x 6 (2units)	1.5 x 6 (2units)	2.2 x 6 (2units)	
	Brake	DC Magnet Disc Brake					
Dimensions (approx.)(mm)		H	1490	1050	1680	1780	1780
	R	1600	1600	2300	2800	2800	
	A	1025	1025	1432	1525	1525	
	B	955	995	1243	1150	1150	
	C	1013	1050	1220	1220	1220	
	G	1455	1645	1780	2030	2030	
	K	1360	1365	1715	1965	1965	
	W	1550	1550	2125	2125	2075	
	D	70	70	80	80	80	
	L	1044	1044	1430	1930	1930	
I-Beam and Spacing (mm)	M	215	215	275	275	300	
	N	215	215	275	275	300	
	P	355	355	450	450	500	
	Q	395	395	490	490	540	
	Min. Radius of Curvature(m)	5200	5336	7000	8500	9000	
Weight (approx.) (kg)		37	37	50	50	50	

## (Low Head Type Hoist with Motor Driven Trolley)

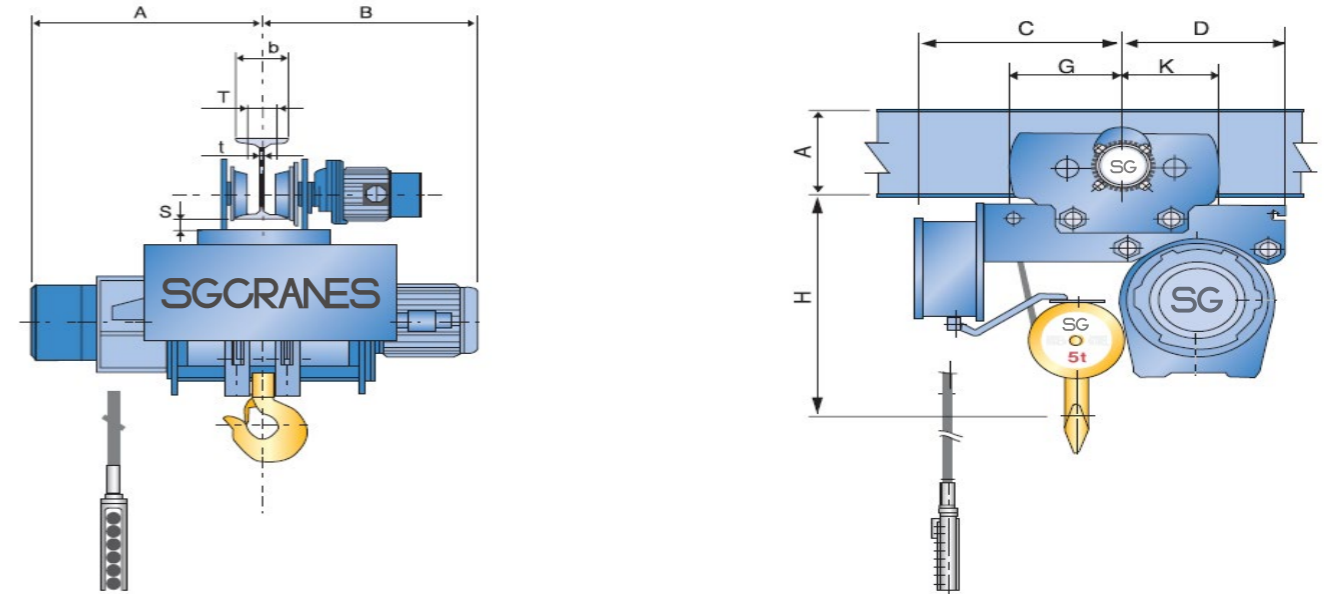

Table

Model		SL 0.5-M	SL 1-M	SL 2-M	SL 2.8-M	SL 3-M	SL 5-M			
Capacity (ton)		1/2	1	2	2.8	3	5			
Type	Hoisting Speed	High-High	SL 0.5-H6-MH	SL 1-H6-MH	SL 2-H6-MH	SL 2.8-H6-MH	SL 3-H6-MH	SL 5-H6-MH		
		High-Low	SL 0.5-H6-ML	SL 1-H6-ML	SL 2-H6-ML	SL 2.8-H6-ML	SL 3-H6-ML	SL 5-H6-ML		
Traversing	Hoisting Speed	High-High	SL 0.5-L6-MH	SL 1-L6-MH	SL 2-L6-MH	SL 2.8-L6-MH	SL 3-L6-MH	SL 5-L6-MH		
		High-Low	SL 0.5-L6-ML	SL 1-L6-ML	SL 2-L6-ML	SL 2.8-L6-ML	SL 3-L6-ML	SL 5-L6-ML		
Hoist	Max. lift(m)	6								
	Hoisting Speed (m/min)	High Speed 50/60(Hz)	10/12	10/12	8.4/10	7.5/9	7.5/9	4.7/5.6		
		Low Speed 50/60(Hz)	5/6	5/6	4.2/5	3.7/4.5	3.7/4.5	3.5/4.2		
	Hoisting Motor (Kw x P)	High Speed	1.2 x 4	2.4 x 4	3.7 x 4	4.8 x 4	5.5 x 4	5.5 x 6		
Low Speed		0.6 x 8	1.2 x 8	1.8 x 8	2.4 x 8	2.8 x 8	4.2 x 8			
Wire Rope	Construction	7 x 19								
	Die(mm) x No. of Ropes	4 x 4	6 x 4	8 x 4	9 x 4	9 x 4	11.2 x 4			
Traversing	Brake	DC Magnet Disc Brake								
		High Speed 50/60(Hz)	20/24							
	Traversing Speed (m/min)	Low Speed 50/60(Hz)	13/16							
		High Speed	0.4 x 4	0.4 x 4	0.75 x 4	0.75 x 4	0.75 x 4	0.75 x 4		
Traversing Motor (Kw x P)	Low Speed	0.2 x 6	0.2 x 6	0.5 x 6	0.5 x 6	0.5 x 6	0.5 x 6			
	Brake	DC Magnet Disc Brake								
Dimensions (approx.)(mm)		H	550	550	620	620	620	800		
	A	465	505	590	620	620	705			
	B	450	480	510	540	540	585			
	C	405	405	435	495	510	585			
	D	245	290	385	395	395	465			
	G	255	255	260	260	260	275			
	K	200	200	225	225	225	275			
I-Beam and Spacing (mm)	a x b x c	S	T	U	S	T	U	S	T	U
	200 x 100 x 7	38	45	144	38	46	144	-	-	-
	250 x 125 x 7.5	30	71	153	30	71	153	22	71	182
	300 x 150 x 10	28	96	155	30	71	153	22	96	182
	450 x 175 x 13	-	-	-	-	-	-	-	-	-
Min. Radius of Curvature(m)		1.5	1.5	1.8	1.8	1.8	2.3	1.8	1.8	2.3
Weight (approx.) (kg)		175	200	350	440	440	730	440	440	730



## (Double Low Head Type Hoist With Motor Driven Trolley)

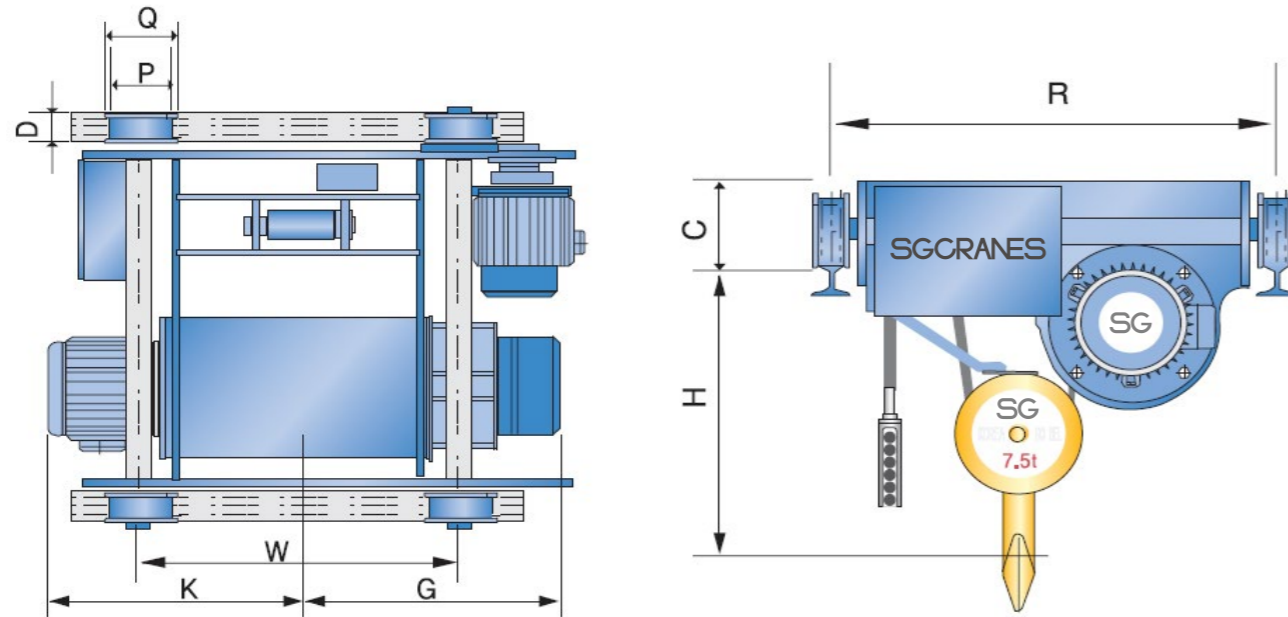

Table

Model		SP 2-M	SP 2.8-M	SP 3-M	SP 5-M	SP 7.5-M	
Capacity (ton)		2	2.8	3	5	7.5	
Type	Hoisting Speed	High-High	SP 2-H6-MH	SP 2.8-H6-MH	SP 3-H6-MH	SP 5-H6-MH	SP 7.5-H12-MH
		High-Low	SP 2-H6-ML	SP 2.8-H6-ML	SP 3-H6-ML	SP 5-H6-ML	SP 7.5-H12-ML
	Traversing	High-High	SP 2-L6-MH	SP 2.8-L6-MH	SP 3-L6-MH	SP 5-L6-MH	SP 7.5-L12-MH
		High-Low	SP 2-L6-ML	SP 2.8-L6-ML	SP 3-L6-ML	SP 5-L6-ML	SP 7.5-L12-ML
Hoist	Max. lift(m)	6(1.2)	6(1.2)	6(1.2)	6(1.1)	12	
	Hoisting Speed (m/min)	High Speed 50/60(Hz)	8.3/10	7.5/9	7.5/9	4.7/5.6	3.2/3.8
		Low Speed 50/60(Hz)	5/6	3.8/4.5	3.8/4.5	3.5/4.2	2.4/2.8
	Hoisting Motor (Kw x P)	High Speed	3.7 x 4	4.8 x 4	5.5 x 4	5.5 x 6	5.5 x 6
		Low Speed	1.8 x 6	2.4 x 8	2.8 x 8	4.2 x 8	4.2 x 8
	Wire Rope	Construction	6 x 37				
Die(mm) x No. of Ropes		8 x 4	9 x 4	9 x 4	11.2 x 4	14 x 4	
Traversing	Brake	DC Magnet Disc Brake					
		Traversing Speed (m/min)	High Speed 50/60(Hz)		20/24	12.5/15	
	Traversing Motor (Kw x P)	Low Speed 50/60(Hz)		13/16	8.3/10		
		High Speed	0.75 x 4	0.75 x 4	0.75 x 4	0.75 x 4	
Dimensions (approx.)(mm)	Brake	DC Magnet Disc Brake					
		H	390	495	525	950	
Dimensions (approx.)(mm)	R	950	950	950	1150	1400	
	C	170	170	170	200	200	
	G	582	652	652	730	925	
	K	532	550	550	620	870	
	W	650	650	650	772	1250	
	D	47	47	47	47	47	
	P	140	140	140	165	165	
	Q	170	170	170	195	195	
Min. Radius of Curvature(m)	15	15	15	15	30		

## (Regular Type Creep Hoist with Motor Driven Trolley)

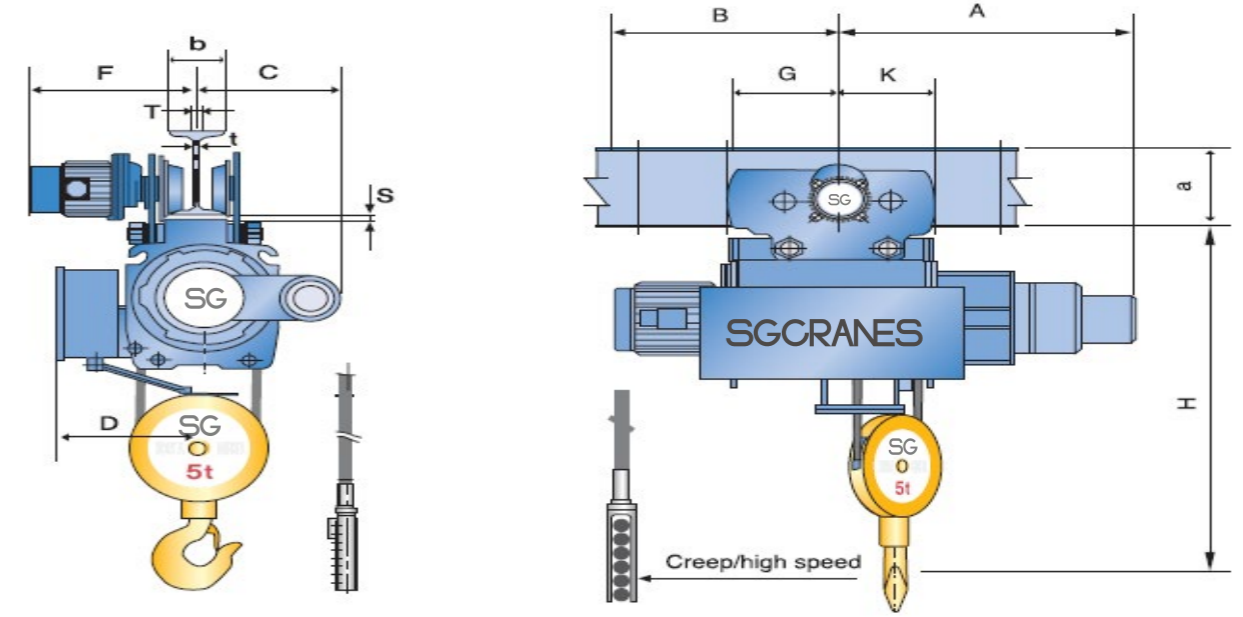

Table

Model		SN 1-M	SN 2-M	SN 2.8-M	SN 3-M	SN 5-M												
Capacity (ton)		1	2	2.8	3	5												
Type	Traversing	High Speed	C-SN 1-H6(12)-MH	C-SN 2-H6(12)-MH	C-SN 2.8-H6(12)-MH	C-SN 3-H6(12)-MH	C-SN 5-H6(12)-MH											
		Low Speed	C-SN 1-H6(12)-ML	C-SN 2-H6(12)-ML	C-SN 2.8-H6(12)-ML	C-SN 3-H6(12)-ML	C-SN 5-H6(12)-ML											
Hoist	Max. lift(m)	6(1.2)																
	Hoisting Speed(m/min)	50Hz	10/1	8.4/0.84	7.5/0.75	7.5/0.75	4.7/0.47											
		High / Creep Speed	60Hz	12/1.2	10/1	9/0.9	9/0.9	5.6/0.56										
	Hoisting Motor(Kw x P)	High / Creep Speed	2.4/0.4 x 4	3.7/0.4 x 4	4.8/1.1 x 4	5.5/1.1 x 4	5.5/1 x 6											
		Construction	6x37															
	Wire Rope	Die(mm) x No. of Ropes	8 x 2	10 x 2	12.5 x 2	12.5 x 2	16 x 2											
Traversing	Brake	DC Magnet Disc Brake																
		Traversing Speed (m/min)	High Speed 50/60(Hz)		20/24	13/16												
	Traversing Motor (Kw x P)	Low Speed 50/60(Hz)		0.4 x 4	0.75 x 4	0.75 x 4	0.75 x 4											
		High Speed	0.2 x 6	0.5 x 6	0.5 x 6	0.5 x 6												
Dimensions (approx.)(mm)	Brake	DC Magnet Disc Brake																
		H	815	980	1115	1115	1325											
I-Beam and Spacing (mm)	A	580(680)	620(720)	740(840)	740(840)	840(940)												
	B	380(480)	410(510)	440(540)	440(540)	500(585)												
	C	275	310	365	380	415												
	D	330	370	375	375	430												
	G	255	260	260	260	275												
	K	200	225	225	225	275												
	I-Beam and Spacing (mm)	a x b x c	C	S	T	U	C	S	T	U	C	S	T	U	C	S	T	U
		200 x 100 x 7	395	38	46	144	-	-	-	-	-	-	-	-	-	-	-	-
250 x 125 x 7.5		395	30	71	153	445	26	71	183	445	25	71	182	445	25	71	182	455
300 x 150 x 10		410	28	96	156	460	24	96	182	460	23	96	182	460	23	96	182	465
450 x 175 x 13		-	-	-	-	-	-	-	-	-	-	-	-	-	-	-	-	480
Min. Radius of Curvature(m)	1.5	1.8	1.8	1.8	2.3													
Weight (approx.) (kg)	225(245)	320(355)	415(460)	415(460)	635(700)													

## (Regular Type Creep Hoist with Motor Driven Trolley)

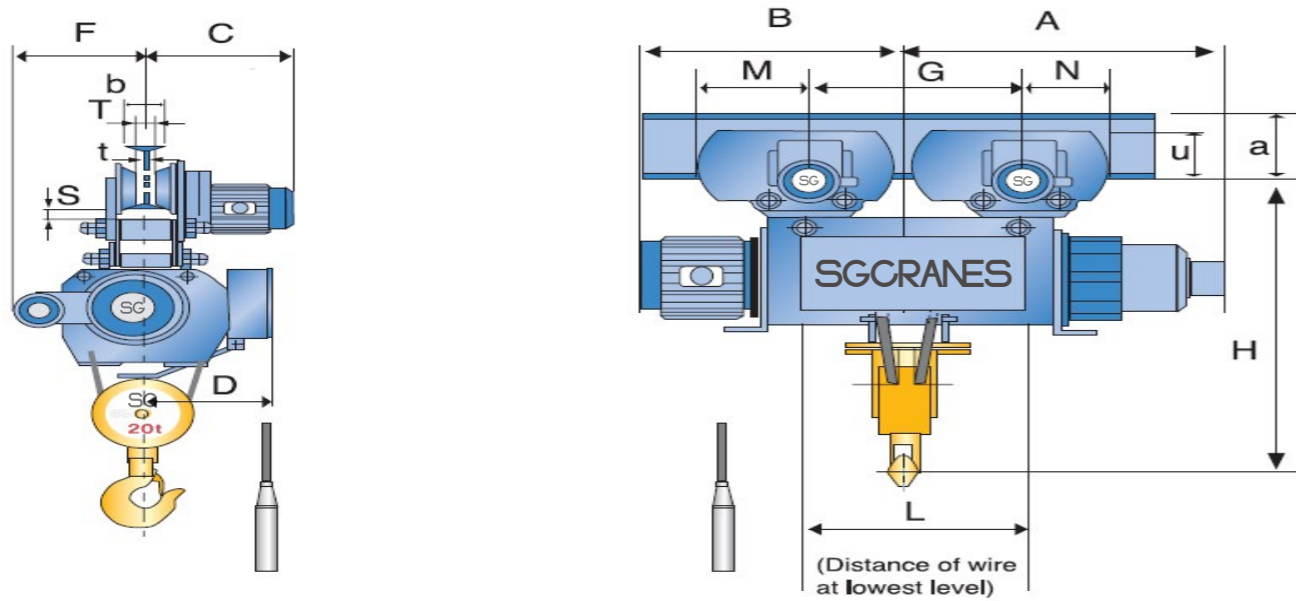

Table

Model		SN 75-M	SN 10-M	SN 15-M	SN 20-M													
Capacity (ton)		75	10	15	20													
Traversing	High Speed	C-SN 75-H12-MH	C-SN 10-H12-MH	C-SN 15-H12-MH	C-SN 20-H12-MH													
	Low Speed	C-SN 75-H12-ML	C-SN 10-H12-ML	C-SN 15-H12-ML	C-SN 20-H12-ML													
Hoist	Max. lift(m)	12																
	Hoisting Speed(m/min)	50Hz	3.1/0.31	3.7/0.37	3.7/0.37	3.5/0.35												
	High / Creep Speed	60Hz	3.8/0.38	4.5/0.45	4.5/0.45	4.2/0.42												
	Hoisting Motor(Kw x P)	High / Creep Speed	5.5/1 x 6	9/1.1 x 8	13/1.8 x 8	17/1.8 x 8												
	Wire Rope	Construction	6x37															
	Die(mm) x No. of Ropes	14 x 4	16 x 4	20 x 4	22.4 x 4													
Traversing	Brake	DC Magnet Disc Brake																
	Traversing Speed (m/min)	High Speed 50/60(Hz)	12.5/15															
		Low Speed 50/60(Hz)	8.3/10															
	Traversing Motor (Kw x P)	High Speed	0.75 x 4	0.75 x 4 (2units)	1.5 x 4 (2units)	1.5 x 4 (2units)												
		Low Speed	0.6 x 6	0.5 x 6 (2units)	1 x 6 (2units)	1 x 6 (2units)												
	Brake	DC Magnet Disc Brake																
Dimensions (approx.)(mm)	H	1460	1565	1875	2115													
	A	1170	1230	1365	1460													
	B	835	955	1005	1220													
	D	480	510	620	640													
	F	465	525	575	621													
	L	850	850	870	935													
	G	800	800	800	850													
	M	276	276	300	300													
	K	276	276	300	300													
I-Beam and Spacing (mm)	a x b x c	C	S	T	U	C	S	T	U	C	S	T	U	C	S	T	U	
	300 x 150 x 10	500	35	68	224	475	35	68	224	-	-	-	-	-	-	-	-	-
	450 x 175 x 10	510	30	93	228	490	30	93	228	580	32	77	248	580	32	77	248	
	600 x 190 x 13	520	32	118	227	495	32	118	227	587	37	92	243	587	37	92	243	
	Min. Radius of Curvature(m)	For straight rails only																
Weight (approx.) (kg)	970		1280				2180				2520							

## (Low Head Type Creep Hoist with Motor Driven Trolley)

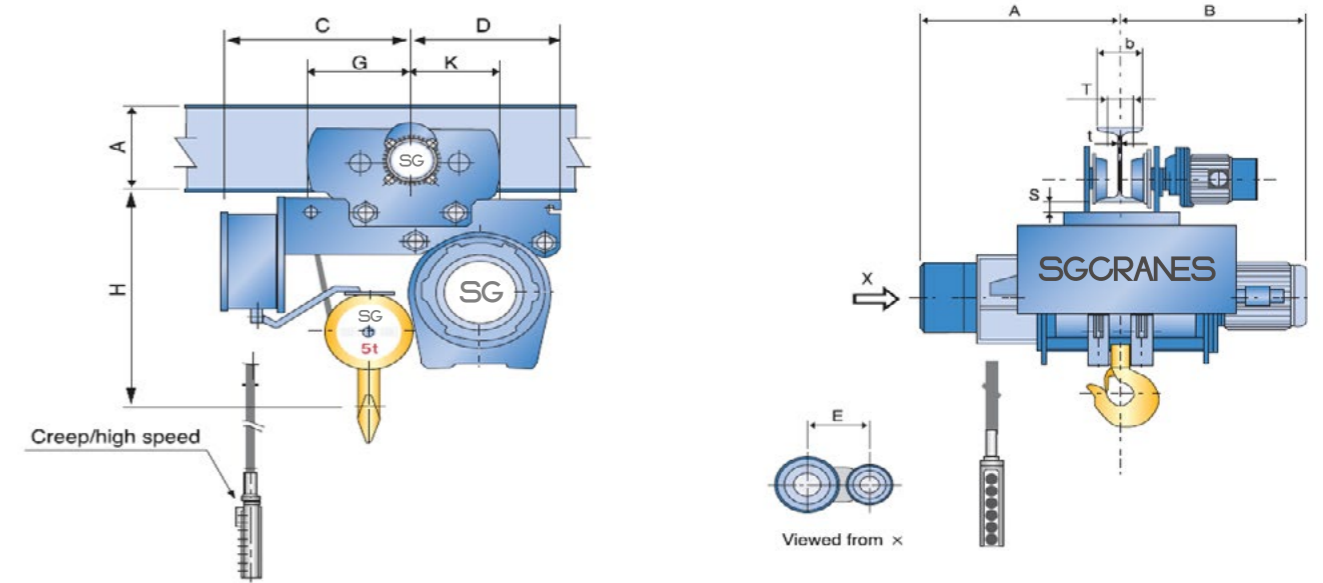

Table

Model		SL 1-M	SL 2-M	SL 2.8-M	SL 3-M	SL 5-M										
Capacity (ton)		1	2	2.8	3	5										
Traversing	High Speed	C-SL 1-H6-MH	C-SL 2-H6-MH	C-SL 2.8-H6-MH	C-SL 3-H6-MH	C-SL 5-H6-MH										
	Low Speed	C-SL 1-H6-ML	C-SL 2-H6-ML	C-SL 2.8-H6-ML	C-SL 3-H6-ML	C-SL 5-H6-ML										
Hoist	Max. lift(m)	6														
	Hoisting Speed(m/min)	50Hz	10/1	8.4/0.84	7.5/0.75	7.5/0.75	4.7/0.47									
	High / Creep Speed	60Hz	12/1.2	10/1	9/0.9	9/0.9	5.6/0.56									
	Hoisting Motor(Kw x P)	High / Creep Speed	2.4/0.4 x 4	3.7/0.4 x 4	4.8/1.1 x 4	5.5/1.1 x 4	5.5/1 x 6									
	Wire Rope	Construction	6x37													
	Die(mm) x No. of Ropes	6 x 4	8 x 4	9 x 4	9 x 4	11.2 x 4										
Traversing	Brake	DC Magnet Disc Brake														
	Traversing Speed (m/min)	High Speed 50/60(Hz)	20/24													
		Low Speed 50/60(Hz)	13/16													
	Traversing Motor (Kw x P)	High Speed	0.4 x 4	0.75 x 4	0.75 x 4	0.75 x 4	0.75 x 4									
		Low Speed	0.2 x 6	0.5 x 6	0.5 x 6	0.5 x 6	0.5 x 6									
	Brake	DC Magnet Disc Brake														
Dimensions (approx.)(mm)	H	550	620	620	620	800										
	A	680	740	840	840	940										
	B	510	765	765	765	820										
	C	450	450	495	510	585										
	D	290	385	400	565	635										
	G	255	260	260	260	275										
	K	200	225	225	225	275										
	E	330	375	375	375	425										
	F	480	555	555	570	600										
I-Beam and Spacing (mm)	a x b x c	C	T	U	C	T	U	C	T	U	C	T	U	C	T	U
	200 x 100 x 7.5	38	46	144	33	46	172	-	-	-	-	-	-	-	-	-
	250 x 125 x 7.5	30	71	153	24	71	182	25	71	182	23	71	182	23	71	182
	300 x 150 x 10	28	96	155	22	96	182	23	96	182	23	96	182	23	96	182
	450 x 175 x 13	-	-	-	-	-	-	-	-	-	-	-	-	-	34	111
Min. Radius of Curvature(m)	1.5		1.8		1.8		1.8		2.8							
Weight (approx.) (kg)	275		440		545		545		775							





## (Double Rail Type Creep Hoist with Motor Driven Trolley)

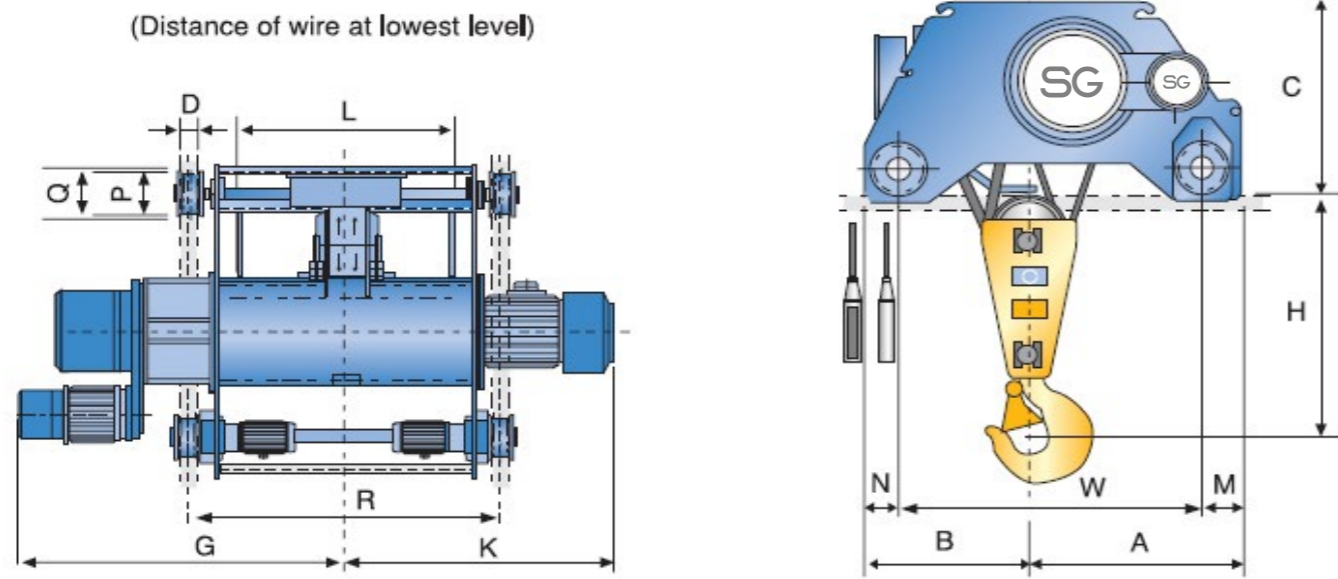

Table

Model		SD 35-M	SD 40-M	SD 50-M	SD 60-M	SD 70-M	
Capacity (ton)		35	40	50	60	70	
Traversing	High Speed	C-SD 35-H12-MH	C-SD 40-H12-MH	C-SD 50-H12-MH	C-SD 60-H12-MH	C-SD 70-H12-MH	
	Low Speed	C-SD 35-H12-ML	C-SD 40-H12-ML	C-SD 50-H12-ML	C-SD 60-H12-ML	C-SD 70-H12-ML	
Hoist	Max. lift(m)	12					
	Hoisting Speed(m/min)	50Hz	4/0.4	2.7/0.27	2/0.2	2/0.2	
	High / Creep Speed	60Hz	4.8/0.48	3.2/0.32	2.4/0.24	2.4/0.24	
	Hoisting Motor(Kw x P) High / Creep Speed		33/3.7 x 6/4	33/3.7 x 6/4	33/3.7 x 6/4	33/3.7 x 6/4	
	Wire Rope	Construction	6 x F(25)				
	Die(mm) x No. of Ropes	28 x 4	28 x 6	28 x 6	28 x 8	28 x 8	
Traversing	Brake	DC Magnet Disc Brake					
	Traversing Speed (m/min)	High Speed 50/60(Hz)	12.5/15	12.5/15	12.5/15	12.5/15	
		Low Speed 50/60(Hz)	8.3/10	8.3/10	8.3/10	8.3/10	
	Traversing Motor (Kw x P)	High Speed	2.2 x 4	2.2 x 4 (2units)	2.2 x 4 (2units)	2.2 x 4 (2units)	3.7 x 4 (2units)
		Low Speed	1.5 x 6	1.5 x 6 (2units)	1.5 x 6 (2units)	1.5 x 6 (2units)	2.2 x 6 (2units)
Dimensions (approx.)(mm)	Brake	DC Magnet Disc Brake					
	H	1490	1500	1680	1780	1780	
	R	1600	1600	2300	2800	2800	
	A	1025	1025	1432	1525	1525	
	B	955	955	1243	1150	1150	
	C	1013	1050	1220	1220	1220	
	G	1735	1735	2060	2310	2310	
	K	1360	1455	1715	1965	1965	
	W	1550	1550	2125	2125	2075	
	D	70	70	80	80	80	
	L	1044	1044	1730	1930	1930	
	M	215	215	275	275	300	
	N	215	215	275	275	300	
	P	355	355	450	450	500	
Q	395	395	490	490	540		
Weight (approx.) (kg)		5400	5400	7200	9050	9200	
Traversing Rail (kg/m)		37	37	50	50	50	

## (Double Rail Type Main & Aux Hoist)

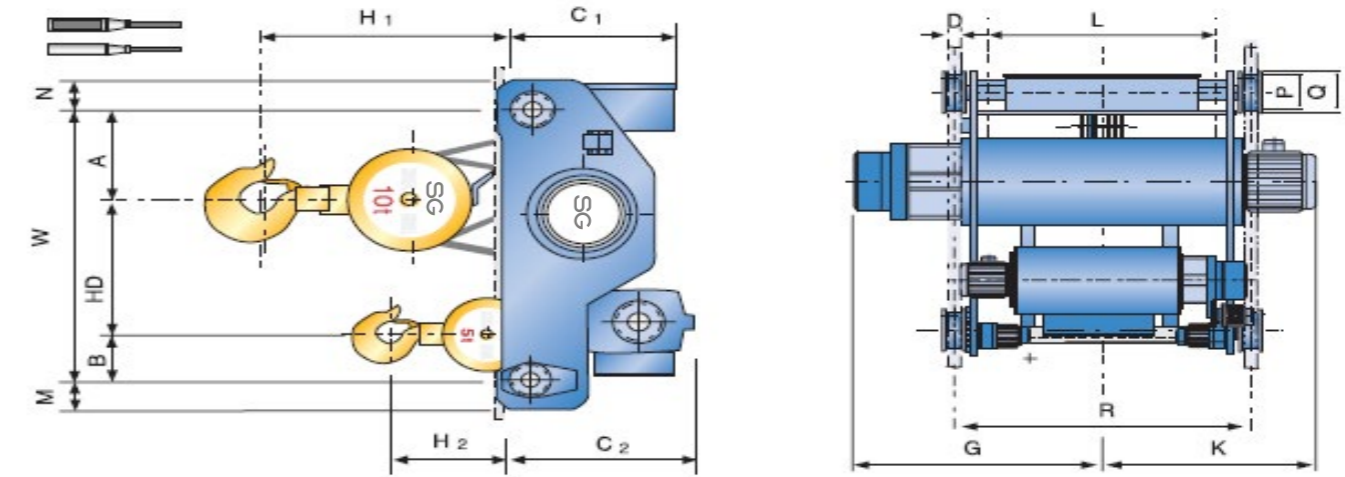

Table

Model		SA 5/3-M	SA 7.5/3-M	SA 10/5-M	SA 15/5-M	
Capacity (ton)		5/3	7.5/3	10/5	15/5	
Hoist	Max. lift(m)	12				
	Traversing	High Speed	4.7/5.6	7.5/9	3.1/3.8	7.5/9
		Low Speed	3.5/4.2	3.7/4.5	2.3/2.8	3.7/4.5
	Hoisting Speed(m/min)	50Hz	5.5 x 6	5.5 x 4	5.5 x 6	5.5 x 4
	High / Creep Speed	60Hz	4.2 x 8	2.8 x 8	4.2 x 8	2.8 x 8
Wire Rope	Construction	6 x 37				
	Die(mm) x No. of Ropes	12.5 x 4	12.5 x 2	14 x 4	12.5 x 2	16 x 4
Traversing	Brake	DC Magnet Disc Brake				
	Traversing Speed (m/min)	High Speed 50/60(Hz)	20/24	12.5/15	12.5/15	12.5/15
		Low Speed 50/60(Hz)	13/16	8.3/10	8.3/10	8.3/10
	Traversing Motor (Kw x P)	High Speed	0.75 x 4	0.75 x 4	0.75 x 4	1.5 x 4
		Low Speed	0.5 x 6	0.5 x 6	0.56 x 6	1 x 6
Dimensions (approx.)(mm)	Brake	DC Magnet Disc Brake				
	H1	510	730	775	995	
	H2	270	350	390	365	
	R	1150	1150	1150	1200	
	HD	485	570	600	645	
	A	370	420	460	425	
	B	365	390	400	450	
	C1	550	550	695	860	
	C2	845	725	905	930	
	G	935	925	975	1075	
	K	885	870	1060	1065	
	W	1220	1380	1460	1520	
	D	47	58	58	58	
	L	890	852	851	872	
M	110	110	110	130		
N	125	120	120	140		
P	165	165	165	180		
Q	190	195	195	210		
Weight (approx.) (kg)		1285	1600	1830	2475	
Traversing Rail (kg/m)		15	15	15	22	

## (Double Rail Type Main & Aux Hoist)

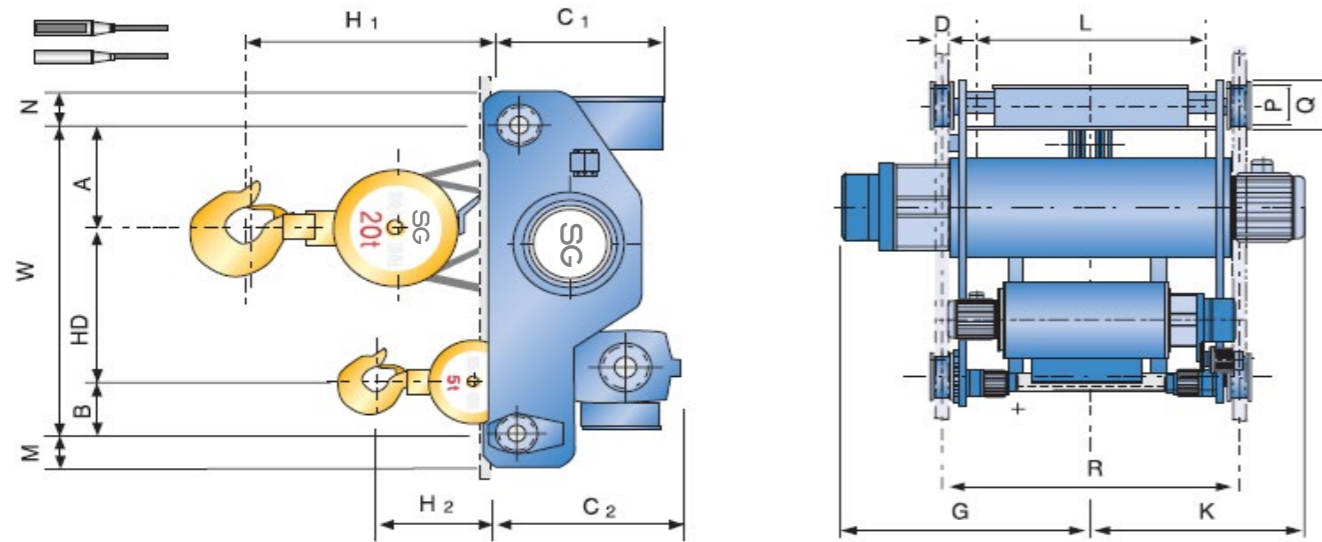

Table

Model		SA 20/5-M	SA 20/10-M	SA 30/10-M	SA 30/15-M	
Capacity (ton)		20/5	20/10	30/10	30/15	
Hoist	Max. lift(m)	12				
	Hoisting Speed (m/min)	High Speed 50/60(Hz)	3.5/4.2	4.7/5.6	3.5/4.2	3.7/4.5
		Low Speed 50/60(Hz)	2.5/2.8	3.5/4.2	2.5/4.2	2.5/3
	Hoisting Motor (Kw x P)	High Speed	17 x 8	5.5 x 6	17 x 8	9 x 8
Low Speed		11.5 x 12	4.2 x 8	11.5 x 12	6 x 12	
Wire Rope	Construction	6 x 37				
	Die(mm) x No. of Ropes	22.4 x 4	16 x 2	22.4 x 4	16 x 4	
Traversing	Brake		DC Magnet Disc Brake			
	Traversing Speed (m/min)	High Speed 50/60(Hz)	12.5/15	12.5/15	12.5/15	12.5/15
		Low Speed 50/60(Hz)	8.3/10	8.3/10	8.3/10	8.3/10
	Traversing Motor (Kw x P)	High Speed	1.5 x 4	1.5 x 4	1.5 x 4(2units)	1.5 x 4(2units)
Low Speed		1 x 6	1 x 6	1 x 6(2units)	1 x 6(2units)	
Dimensions (approx.)(mm)	Brake		DC Magnet Disc Brake			
	H1	1175	1175	1480	1480	
	H2	350	425	430	615	
	R	1300	1300	1800	1800	
	HD	700	775	1010	1010	
	A	570	575	780	780	
	B	450	630	550	550	
	C1	900	900	980	980	
	C2	935	1180	995	1115	
	G	1165	1165	1425	1425	
	K	1210	1210	1480	1480	
	W	1720	1980	2340	2340	
	D	58	58	70	70	
	L	934	934	1418	1418	
	M	170	170	160	160	
	N	170	170	180	180	
P	220	220	250	250		
Q	250	250	280	280		
Weight (approx.) (kg)		2925	3475	4670	5200	
Traversing Rail (kg/m)		22	22	30	30	

## (Double Rail Type Main & Aux Hoist)

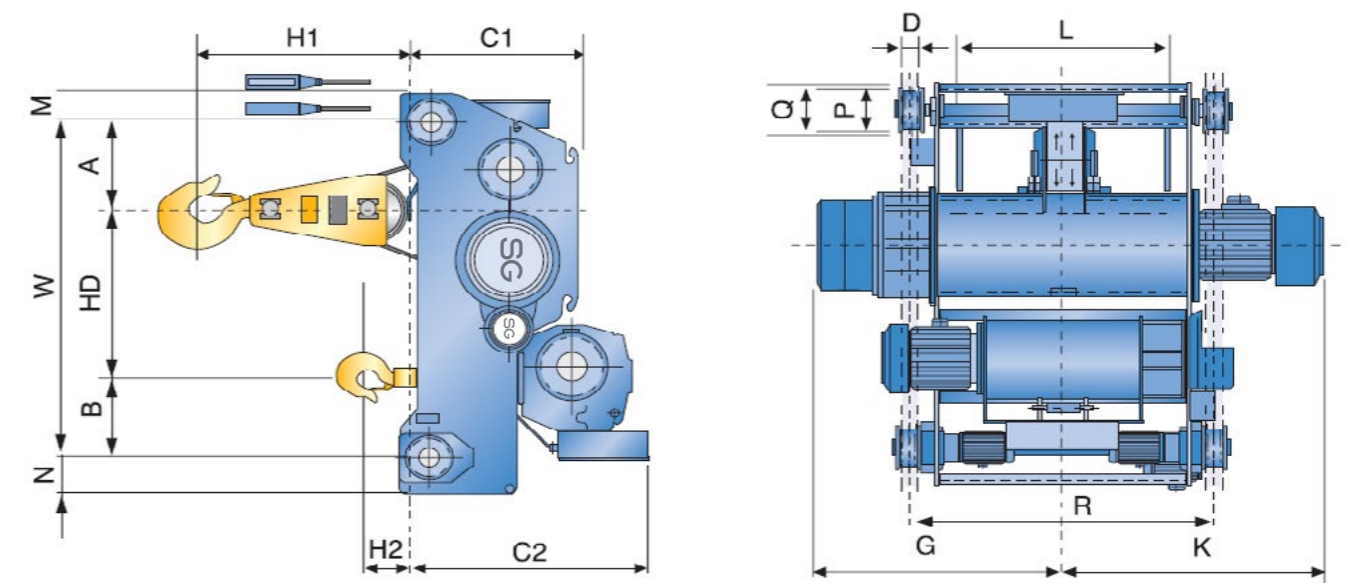

Table

Model		SA 35/10-M	SA 50/10-M	SA 60/20-M	SD 70/20-M	
Capacity (ton)		35/10	50/10	60/20	70/20	
Hoist	Max. lift(m)	12				
	Traversing	High Speed	4/4.8	3.7/4.5	2.7/3.2	3.7/4.5
		Low Speed	2.5/3	2.5/3	2/2.4	3.5/4.2
	Hoisting Speed(m/min)	50Hz	9 x 8	33 X 6	9 x 8	17 x 8
High / Creep Speed		6 x 12	33 X 6	6 x 12	11.5 x 12	
Wire Rope	Construction	6 x Fi(25)	6 x 37	6 x Fi(25)	6 x 37	
	Die(mm) x No. of Ropes	28 x 4	16 x 4	28 x 6	16 x 4	
Traversing	Brake		DC Magnet Disc Brake			
	Traversing Speed (m/min)	High Speed 50/60(Hz)	12.5/15	12.5/15	12.5/15	12.5/15
		Low Speed 50/60(Hz)	8.3/10	8.3/10	8.3/10	8.3/10
	Traversing Motor (Kw x P)	High Speed	2.2 x 4	2.2 x 4(2units)	2.2 x 4(2units)	3.7 x 4(2units)
Low Speed		1.5 x 6	1.5 x 6(2units)	1.5 x 6(2units)	2.2 x 6(2units)	
Dimensions (approx.)(mm)	Brake		DC Magnet Disc Brake			
	H1	1490	1680	1780	1780	
	H2	420	50	330	330	
	R	1600	2300	2800	2800	
	HD	1100	1300	1378	1378	
	A	740	968	968	968	
	B	560	657	579	579	
	C1	1013	1220	1220	1220	
	C2	1333	1460	1750	1750	
	G	1455	1780	2030	2030	
	K	1360	1715	1965	1965	
	W	2400	2925	2925	2925	
	D	70	80	80	80	
	L	1044	1430	1930	1930	
	M	215	275	275	275	
	N	215	275	275	275	
P	355	450	450	500		
Q	395	490	490	540		
Weight (approx.) (kg)		6400	8200	10930	11080	
Traversing Rail (kg/m)		37	50	50	50	

## (Double Rail Type Creep Main & Aux Hoist)

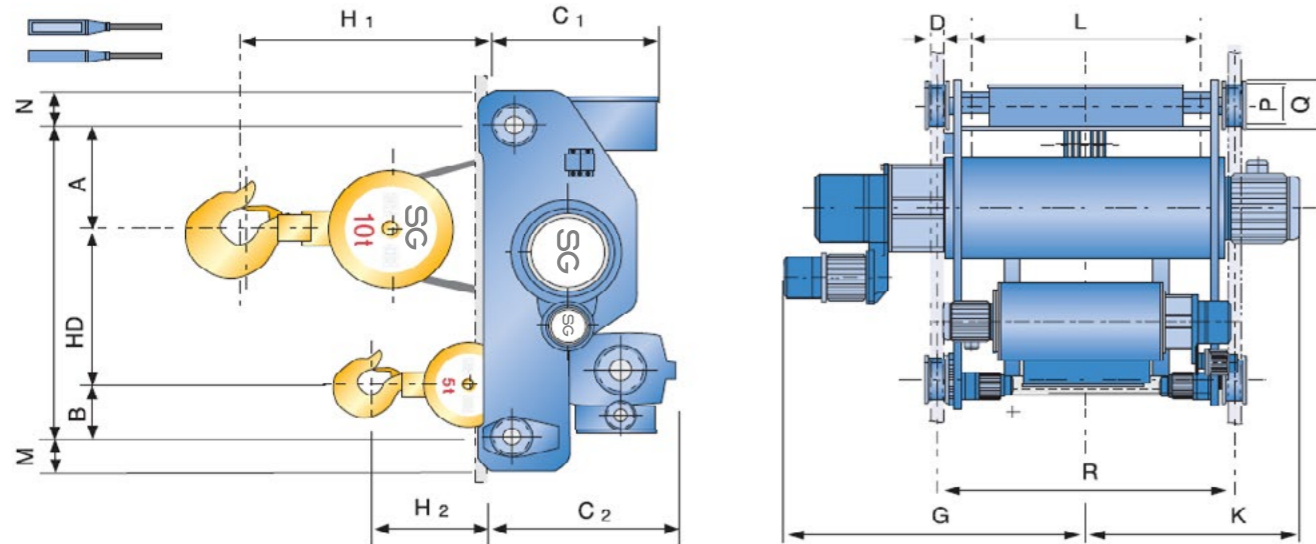

Table

Model		SA 5/3-M	SA 7.5/3-M	SA 10/5-M	SA 15/5-M					
Capacity (ton)		5/3	7.5/3	10/5	15/5					
Hoist	Max. lift(m)	12								
	Hoisting Speed (m/min)	High Speed 50/60(Hz)	4.7/0.47	7.5/0.75	3.1/0.31	7.5/0.75	3.7/0.37	4.7/0.47	3.7/0.37	4.7/0.47
		Low Speed 50/60(Hz)	5.6/0.56	9/0.9	2.3/2.8	9/0.9	4.5/0.45	5.5/0.56	4.5/0.45	5.6/0.56
	Hoisting Motor (Kw x P)	High Speed	5.5/1 x 6	5.5/1.1 x 4	5.5/1 x 6	5.5/1.1 x 4	9/1.1 x 8	5.5/1 x 6	13/1.8 x 8	5.5/1 x 6
Low Speed										
Wire Rope	Construction	6 x 37								
	Die(mm) x No. of Ropes	12.5 x 4	12.5 x 2	14 x 4	12.5 x 2	16 x 4	16 x 2	20 x 4	16 x 2	
Traversing	Brake									
	DC Magnet Disc Brake									
	Traversing Speed (m/min)	High Speed 50/60(Hz)	20/24	12.5/15	12.5/15	12.5/15	12.5/15	12.5/15	12.5/15	12.5/15
		Low Speed 50/60(Hz)	13/16	8.3/10	8.3/10	8.3/10	8.3/10	8.3/10	8.3/10	8.3/10
Traversing Motor (Kw x P)	High Speed	0.75 x 4	0.75 x 4	0.75 x 4	0.75 x 4	0.75 x 4	0.75 x 4	1.5 x 4	1.5 x 4	
	Low Speed	0.5 x 6	0.5 x 6	0.5 x 6	0.5 x 6	0.5 x 6	0.5 x 6	1 x 6	1 x 6	
Dimensions (approx.)(mm)	Brake									
	DC Magnet Disc Brake									
	H1	510	730	775	995					
	H2	270	350	390	365					
	R	1150	1150	1150	1200					
	HD	485	570	600	645					
	A	370	420	460	425					
	B	365	390	400	450					
	C1	550	550	695	860					
	C2	845	725	905	930					
	G	1170	1185	1275	1385					
	K	885	870	1060	1065					
	W	1220	1380	1460	1520					
	D	47	58	58	58					
	L	890	852	851	872					
	M	110	110	110	130					
N	125	120	120	140						
P	165	165	165	180						
Q	190	195	195	210						
Weight (approx.) (kg)		1385	1690	1950	2605					
Traversing Rail (kg/m)		15	15	15	22					

## (Double Rail Type Creep Main & Aux Hoist)

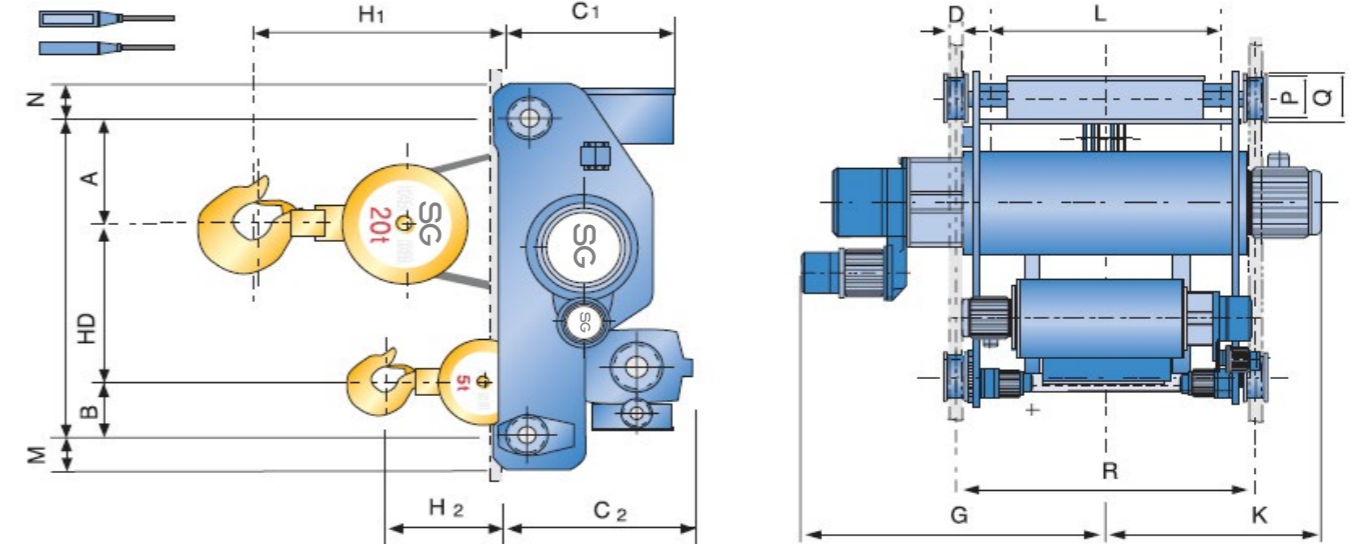

Table

Model		SA 20/5-M	SA 20/10-M	SA 30/10-M	SA 30/15-M					
Capacity (ton)		20/5	20/10	30/10	30/15					
Hoist	Max. lift(m)	12								
	Hoisting Speed (m/min)	50Hz	3.5/0.35	4.7/0.47	3.5/0.35	3.7/0.37	2.3/0.23	3.7/0.37	2.3/0.23	3.7/0.37
		60Hz	4.2/0.42	5.6/0.56	4.2/0.42	4.5/0.45	2.8/0.28	4.5/0.45	2.8/0.28	4.5/0.45
	Hoisting Motor (Kw x P)	High Speed	17/1.8 x 8	5.5/1 x 6	17/1.8 x 8	9/1.1 x 8	17/1.8 x 8	9/1.1 x 8	17/1.8 x 8	13/1.8 x 8
Low Speed										
Wire Rope	Construction	6 x 37								
	Die(mm) x No. of Ropes	22.4 x 4	16 x 2	22.4 x 4	16 x 4	22.4 x 6	16 x 4	22.4 x 6	20 x 4	
Traversing	Brake									
	DC Magnet Disc Brake									
	Traversing Speed (m/min)	High Speed 50/60(Hz)	12.5/15	12.5/15	12.5/15	12.5/15	12.5/15	12.5/15	12.5/15	12.5/15
		Low Speed 50/60(Hz)	8.3/10	8.3/10	8.3/10	8.3/10	8.3/10	8.3/10	8.3/10	8.3/10
Traversing Motor (Kw x P)	High Speed	1.5 x 4	1.5 x 4	1.5 x 4	1.5 x 4(2units)	1.5 x 4(2units)	1.5 x 4(2units)	1.5 x 4(2units)	1.5 x 4(2units)	
	Low Speed	1 x 6	1 x 6	1 x 6	1 x 6(2units)	1 x 6(2units)	1 x 6(2units)	1 x 6(2units)	1 x 6(2units)	
Dimensions (approx.)(mm)	Brake									
	DC Magnet Disc Brake									
	H1	1175	1175	1480	1480					
	H2	350	425	430	615					
	R	1300	1300	1800	1800					
	HD	700	775	1010	1010					
	A	570	575	780	780					
	B	450	630	550	550					
	C1	900	900	980	980					
	C2	935	1180	995	1115					
	G	1480	1480	1740	1740					
	K	1210	1210	1480	1480					
	W	1720	1980	2340	2340					
	D	58	58	70	70					
	L	934	934	1418	1418					
	M	170	170	160	160					
N	170	170	180	180						
P	220	220	250	250						
Q	250	250	280	280						
Weight (approx.) (kg)		3070	3600	4820	5320					
Traversing Rail (kg/m)		22	22	30	30					



## (Double Rail Type Creep Main & Aux Hoist)

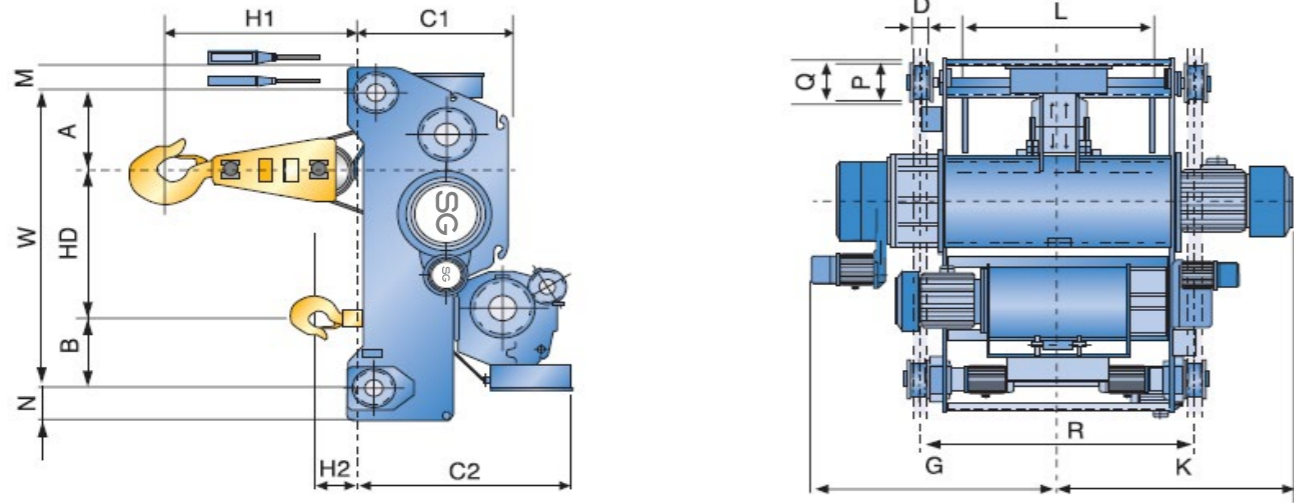

Table

Model		SA 35/10-M	SA 50/10-M	SA 60/20-M	SD 70/20-M					
Capacity (ton)		35/10	50/10	60/20	70/20					
Hoist	Max. lift(m)	12								
	Hoisting Speed (m/min)	High Speed 50/60(Hz)	4/0.4	3.7/0.37	2.7/0.27	3.7/0.37	2/0.2	3.5/0.35	2/0.2	3.5/0.35
		Low Speed 50/60(Hz)	4.8/0.48	4.5/0.45	3.2/0.32	4.5/0.45	2.4/0.24	4.2/0.42	2.4/0.24	4.2/0.42
	Hoisting Motor (Kw x P)	High Speed	33/3.7 x 6/4	9/1.1 x 8	33/3.7 x 6/4	9/1.1 x 8	33/3.7 x 6/4	17/1.8 x 8	33/3.7 x 6/4	17/1.8 x 8
		Low Speed								
Wire Rope	Construction	6 x Fi(25)	6 x 37	6 x Fi(25)	6 x 37	6 x Fi(25)	6 x 37	6 x Fi(25)	6 x 37	
	Die(mm) x No. of Ropes	28 x 4	16 x 4	28 x 6	16 x 4	28 x 8	22.4 x 4	28 x 8	22.4 x 4	
Traversing	Brake		DC Magnet Disc Brake							
	Traversing Speed (m/min)	High Speed 50/60(Hz)	12.5/15	12.5/15	12.5/15	12.5/15				
		Low Speed 50/60(Hz)	8.3/10	8.3/10	8.3/10	8.3/10				
	Traversing Motor (Kw x P)	High Speed	2.2 x 4	2.2 x 4(2units)	2.2 x 4(2units)	3.7 x 4(2units)				
Low Speed		1.5 x 6	1.5 x 6(2units)	1.5 x 6(2units)	2.2 x 6(2units)					
Dimensions (approx)(mm)	Brake		DC Magnet Disc Brake							
	H1	1490	1680	1780	1780					
	H2	420	50	330	330					
	R	1600	2300	2800	2800					
	HD	1100	1300	1378	1378					
	A	740	968	968	968					
	B	560	657	579	579					
	C1	1013	1220	1220	1220					
	C2	1333	1460	1750	1750					
	G	1735	2060	2310	2310					
	K	1360	1715	1965	1965					
	W	2400	2925	2925	2925					
	D	70	80	80	80					
	L	1044	1430	1930	1930					
	M	215	275	275	275					
	N	215	275	275	275					
	P	355	450	450	500					
Q	395	490	490	540						
Weight (approx) (kg)		6700	8500	11290	11440					
Traversing Rail (kg/m)		37	50	50	50					

## (Monorail)

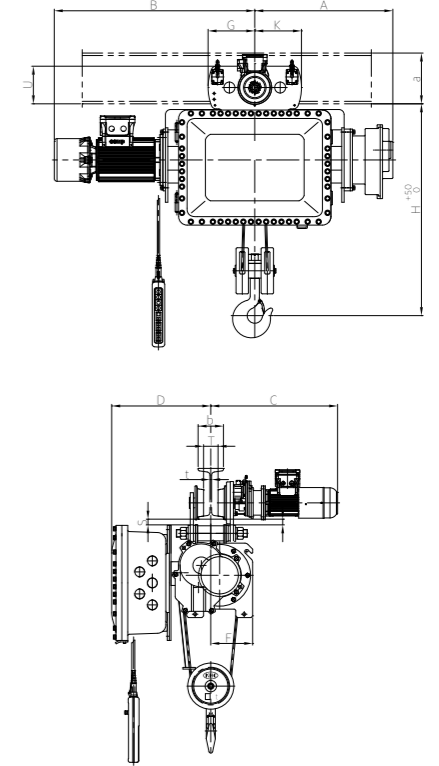

Table

Model		ZSN 1-M	ZSN 2-M	ZSN 3-M	ZSN 5-M																
Capacity (ton)		1	2	3	5																
Hoist	Max. lift(m)	12																			
	Hoisting Speed (m/min)	High Speed 50/60(Hz)	9.2/11	4.6/5.5	5/6	5/6															
		Low Speed 50/60(Hz)	6.1/7.3	3.1/3.7	3.3/4	3.3/4															
	Hoisting Motor (Kw x P)	High Speed	2.2 x 4	2.2 x 4	3.7 x 4	5.5 x 4															
		Low Speed	1.5 x 6	1.5 x 6	2.2 x 6	3.7 x 6															
Wire Rope	Construction	6 x 19	6 x WS(36)	6 x WS(36)	6 x SES(37)																
	Die(mm) x No. of Ropes	6 x 4	8 x 4	9 x 4	11.2 x 4																
Traversing	Brake		DC magnet disc																		
	Traversing Speed (m/min)	High Speed 50/60(Hz)	20/24																		
		Low Speed 50/60(Hz)	13.3/16																		
	Traversing Motor (Kw x P)	High Speed	0.75 x 4	0.75 x 4	0.75 x 4	0.75 x 4															
Low Speed		0.5 x 6	0.5 x 6	0.5 x 6	0.5 x 6																
Dimensions (approx)(mm)	Brake		DC magnet disc																		
	H	800	900	1000	1250																
	A	526	611	647	816																
	B	760	955	1030	1032																
	D	380	566	594	416																
	G	209	225	225	276																
	K	209	225	225	276																
	I-Beam and Spacing (mm)	a x b x t	C	S	F	T	U	C	S	F	T	U	C	S	F	T	U				
200 x 100 x 7		710	39	185	46	254	717	34	200	46	267	717	34	217	46	267	-	-	-	-	
250 x 125 x 7.5		723	37	185	71	256	730	32	200	71	269	730	32	217	71	269	737	40	248	60	286
300 x 150 x 10		736	31	185	96	262	742	26	200	96	275	742	26	217	96	275	750	35	248	85	292
450 x 175 x 13		-	-	-	-	-	-	-	-	-	-	-	-	-	-	-	762	26	248	110	300
Weight (approx) (kg)		1.5			1.8			1.8			2.3										
Traversing Rail (kg/m)		340			450			590			840										



## (Monorail)

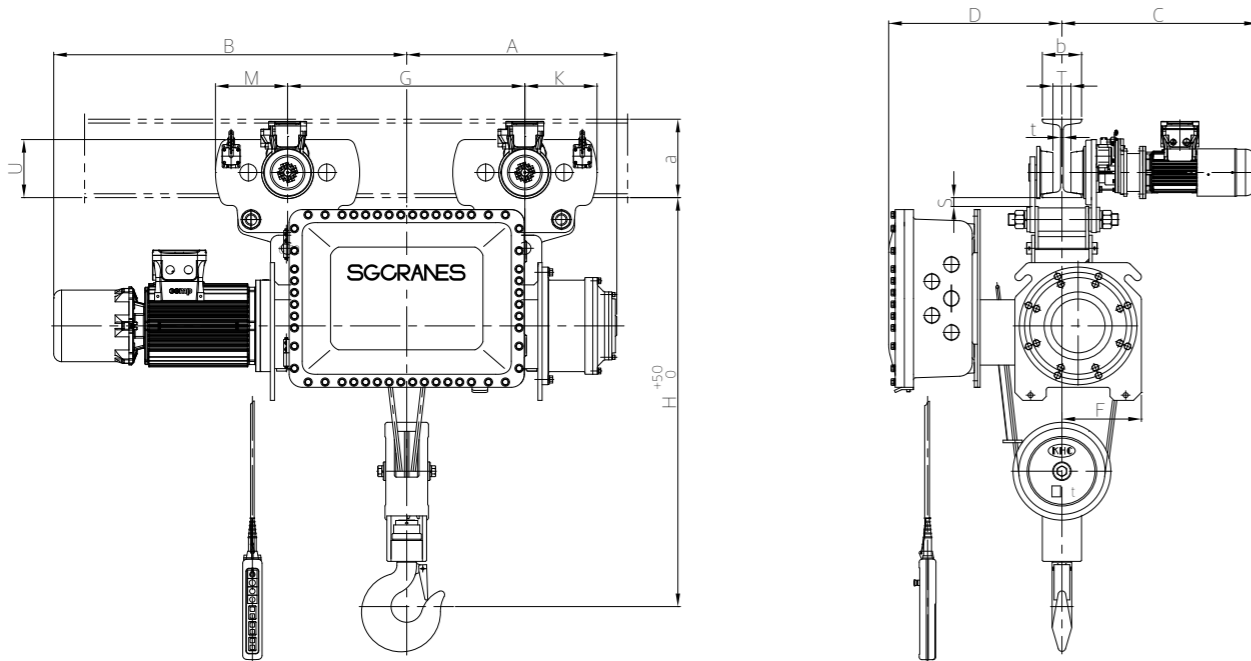

Table

Model		Z-SN 75-M	Z-SN 10-M	Z-SN 15-M	Z-SN 20-M	Z-SN 30-M																				
Capacity (ton)		7.5	10	15	20	30																				
Max. lift(m)		12																								
Hoist	Hoisting Speed (m/min)	High Speed 50/60(Hz)	4.2/5	3.8/4.5	3.8/4.5	3.8/4.5	2.6/3.1																			
		Low Speed 50/60(Hz)	2.8/3.3	2.5/3	2.5/3	2.5/3	1.7/2																			
	Hoisting Motor (Kw x P)	High Speed	7.5 x 4	11 x 4	15 x 4	18.5 x 4	18.5 x 4																			
		Low Speed	5.5 x 6	7.5 x 6	11 x 6	15 x 6	15 x 6																			
Wire Rope	Construction	6 x WS(36)	6 x 37	6 x 37	6 x 37	6 x Fi(29)																				
	Die(mm) x No. of Ropes	14 x 4	16 x 4	20 x 4	22.4 x 4	25 x 4																				
Brake		DC magnet disc																								
Traversing	Traversing Speed (m/min)	High Speed 50/60(Hz)	12.5/15			15/18																				
		Low Speed 50/60(Hz)	8.3/10			10/12																				
	Traversing Motor (Kw x P)	High Speed	0.75 x 4	0.75 x 4	1.5 x 4 (2units)	1.5 x 4 (2units)	1.5 x 4 (2units)																			
		Low Speed	0.5 x 6	0.5 x 6	1.0 x 6 (2units)	1.0 x 6 (2units)	1.0 x 6 (2units)																			
Brake		DC magnet disc																								
Dimensions (approx)(mm)	H	1460	1520	1875	2115	2300																				
	A	772	804	887	948	1009																				
	B	1270	1351	1384	1897	1905																				
	D	670	673	757	761	809																				
	G	908	908	920	994	964																				
	K	276	276	291	291	319																				
	M	250	250	291	291	319																				
	a x b x t	C	S	F	T	U	C	S	F	T	U	C	S	F	T	U										
I-Beam and Spacing (mm)	200 x 100 x 7	748	34	290	69	222	748	34	304	69	292	845	12	360	77	320	845	12	380	77	320	851	22	415	73	329
	250 x 125 x 7.5	760	26	290	94	230	760	26	304	94	300	845	12	360	92	319	853	13	380	92	319	859	23	415	88	328
	300 x 150 x 10											853	13	360	92	319	853	13	380	92	319	859	23	415	88	328
Min. Radius of Curvature(m)		For straight rails only																								
Weight (approx.) (kg)		1000	1230	2233	2695	4050																				

## (Double Rail)

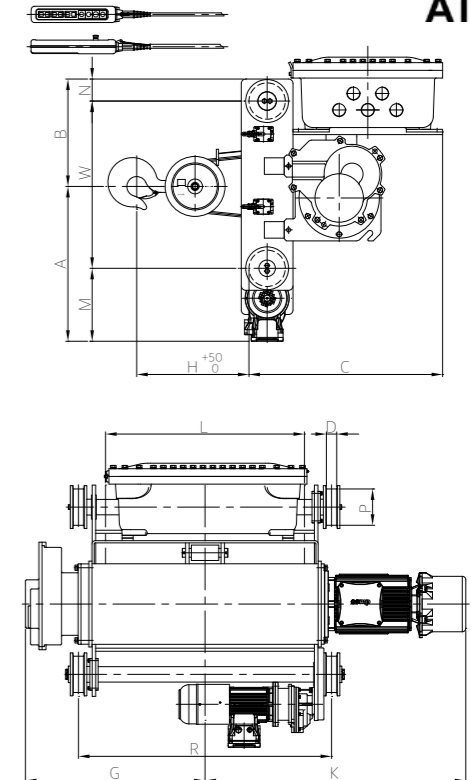

Table

Model		Z-SD 2-M	Z-SD 3-M	Z-SD 5-M	
Capacity (ton)		2	3	5	
Max. lift(m)		12			
Hoist	Hoisting Speed (m/min)	High Speed 50/60(Hz)	4.6/5.5	5/6	5/6
		Low Speed 50/60(Hz)	3.1/3.7	3.3/4	3.3/4
	Hoisting Motor (Kw x P)	High Speed	2.2 x 4	3.7 x 4	5.5 x 4
		Low Speed	1.5 x 6	2.2 x 6	3.7 x 6
Wire Rope	Construction	6 x WS(36)	6 x WS(36)	6 x SES(37)	
	Die(mm) x No. of Ropes	8 x 4	9 x 4	11.2 x 4	
Brake		DC magnet disc			
Traversing	Traversing Speed (m/min)	High Speed 50/60(Hz)	20/24	13.3/16	
		Low Speed 50/60(Hz)	0.75 x 4	0.75 x 4	0.75 x 4
Traversing Motor (Kw x P)	High Speed	0.75 x 4	0.75 x 4	0.75 x 4	
	Low Speed	0.5 x 6	0.5 x 6	0.5 x 6	
Brake		DC magnet disc			
Dimensions (approx)(mm)	H	350	420	510	
	R	900	900	1150	
	A	624	631	704	
	B	387	410	488	
	C	860	860	880	
	G	611	647	816	
	K	955	1030	1185	
	W	590	620	760	
	D	47	47	47	
	L	699	690	904	
	M(N)	326(95)	326(95)	332(100)	
P	140	140	165		
Weight (approx.) (kg)		590	720	1030	
Traversing Rail (kg/m)		15	15	15	

## (Double Rail)

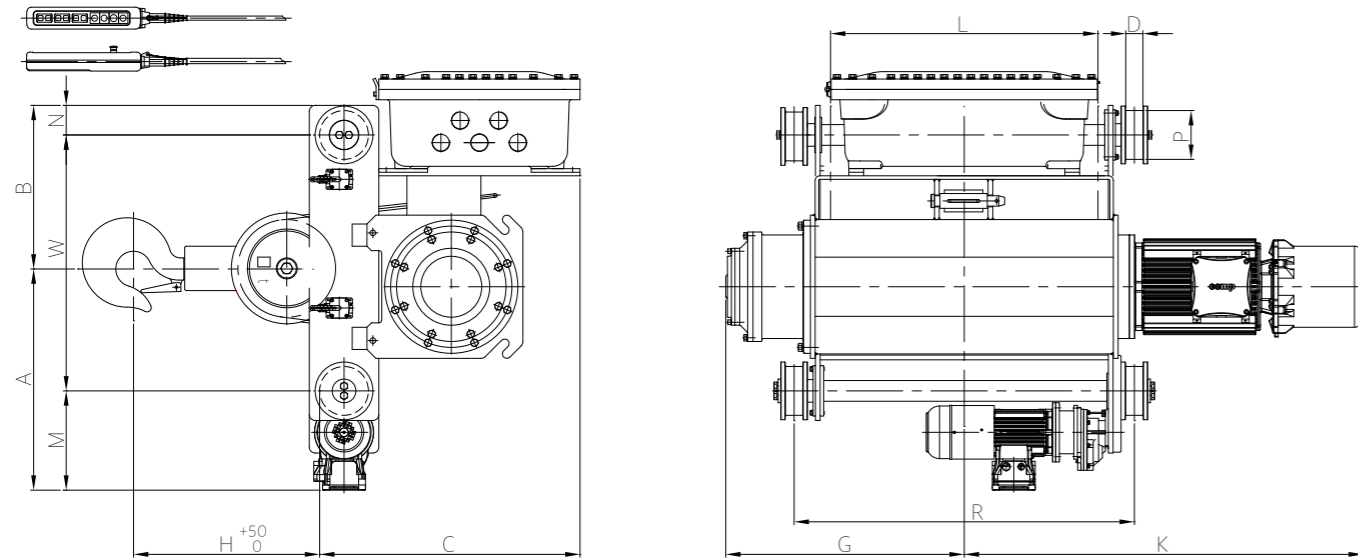

Table

Model		ZSD 75-M	ZSD 10-M	ZSD 15-M	ZSD 20-M	ZSD 30-M	
Capacity (ton)		75	10	15	20	30	
Max. lift(m)		12					
Hoist	Hoisting Speed (m/min)	High Speed 50/60(Hz)	4.2/5	3.8/4.5	3.8/4.5	3.8/4.5	2.6/3.1
		Low Speed 50/60(Hz)	2.8/3.3	2.5/3	2.5/3	2.5/3	1.7/2
	Hoisting Motor (Kw x P)	High Speed	75 x 4	11 x 4	15 x 4	18.5 x 4	18.5 x 4
		Low Speed	5.5 x 6	7.5 x 6	11 x 6	15 x 6	15 x 6
Wire Rope	Construction	6 x WS(36)	6 x 37	6 x 37	6 x 37	6 x Fi(29)	
	Die(mm) x No. of Ropes	14 x 4	16 x 4	20 x 4	22.4 x 4	25 x 4	
Brake		DC magnet disc					
Traversing	Traversing Speed (m/min)	High Speed 50/60(Hz)	12.5/15	12.5/15	16.7/20	16.7/20	12.5/15
		Low Speed 50/60(Hz)	8.3/10	8.3/10	10.8/13	10.8/13	8.3/10
	Traversing Motor (Kw x P)	High Speed	0.75 x 4	0.75 x 4	1.5 x 4	1.5 x 4	2.2 x 4
		Low Speed	0.5 x 6	0.5 x 6	1.0 x 6	1.0 x 6	1.5 x 6
Brake		DC magnet disc					
Dimensions (approx.)(mm)	H	600	630	870	1020	1050	
	R	1150	1150	1200	1300	1300	
	A	736	748	818	863	961	
	B	510	553	600	648	731	
	C	880	880	900	930	985	
	G	772	806	887	948	1009	
	K	1270	1351	1384	1897	1905	
	W	810	865	945	1000	1126	
	D	58	58	58	58	70	
	L	849	832	872	922	925	
	M(N)	336(100)	336(100)	353(120)	371(140)	406(160)	
	P	165	165	180	220	250	
	Weight (approx.) (kg)	1050	1400	2110	2695	3740	
	Rail (kg/m)	15	15	22	22	30	

## (Double Rail)

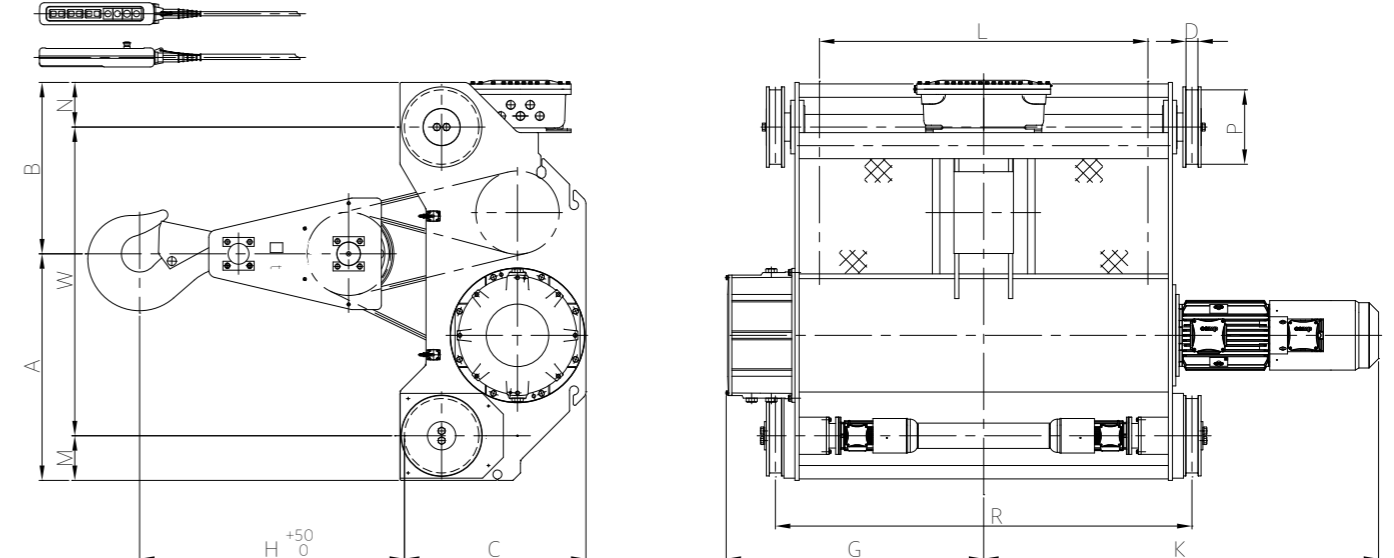

Table

Model		ZSD 40-M	ZSD 50-M	ZSD 60-M	ZSD 70-M	ZSD 80-M	ZSD 100-M	
Capacity (ton)		40	50	60	70	80	100	
Max. lift(m)		12						
Hoist	Hoisting Speed (m/min)	High Speed 50/60(Hz)	3.5/4.2	2.7/3.2	2/2.4	2/2.4	1.8/2.1	1.3/1.6
		Low Speed 50/60(Hz)	2.3/2.8	1.8/2.1	1.3/1.6	1.3/1.6	1.2/1.4	1/1.2
	Hoisting Motor (Kw x P)	High Speed	37 x 6	37 x 6	37 x 6	37 x 6	37 x 6	37 x 6
		Low Speed	30 x 8	30 x 8	30 x 8	30 x 8	30 x 8	30 x 8
Wire Rope	Construction	6 x Fi(29)	6 x Fi(29)	6 x Fi(29)	6 x Fi(29)	6 x Fi(29)	6 x Fi(29)	
	Die(mm) x No. of Ropes	28 x 4	28 x 6	28 x 8	28 x 8	28 x 8	33.5 x 6	
Brake		DC magnet disc						
Traversing	Traversing Speed (m/min)	High Speed 50/60(Hz)	12.5/15	12.5/15	12.5/15	12.5/15	12.5/15	12.5/15
		Low Speed 50/60(Hz)	8.3/10	8.3/10	8.3/10	8.3/10	8.3/10	8.3/10
	Traversing Motor (Kw x P)	High Speed	2.2 x 4	2.2 x 4 (2units)	2.2 x 4 (2units)	2.2 x 4 (2units)	2.2 x 4 (2units)	3.7 x 4 (2units)
		Low Speed	1.5 x 6	1.5 x 6 (2units)	1.5 x 6 (2units)	1.5 x 6 (2units)	1.5 x 6 (2units)	2.2 x 6 (2units)
Brake		DC magnet disc						
Dimensions (approx.)(mm)	H	1490	1680	1780	1780	1780	2000	
	R	1600	2300	2800	2800	2800	2100	
	A	1025	1432	1523	1523	1523	1380	
	B	955	1243	1152	1152	1152	1370	
	C	1013	1220	1220	1220	1220	1220	
	G	1255	1550	1800	1800	1800	2000	
	K	2080	2405	2655	2655	2655	2553	
	W	1550	2125	2125	2075	2075	2150	
	D	70	80	80	80	80	80	
	L	1075	1525	1975	1975	1975	1680	
	M(N)	215(215)	275(275)	275(275)	300(300)	300(300)	300(300)	
	P	355	450	450	500	500	500	
	Weight (approx.) (kg)	5720	7700	9735	9900	9920	12100	
	Rail (kg/m)	37	50	50	50	50	50	

Selection Criteria

You can use CHAIN HOIST for a long time without any trouble if you select it properly according SGRANES Chain Hoists are allocated to mechanism groups in accordance with the following regulations. Under the allowance of the following mechanism groups, the hoist should be operated and should not exceed the nominal values. On each identification plate. the following is indicated.

Hook suspension chain hoist : FEM 9,511 (Hoist = FEM 2m 40% ED)

Motor trolley mounted series : FEM 9.511 (Hoist / Trolley + FEM 2m 1Am 40 / 25% ED) Starting frequency = 240 time / Hr.

FEM Mechansim Group 9.511

(Rules for Design of Serial Lifting Equipment : Classification of Mechanism)

Mechanism group	1Bm	1Am	2m	3m	4m	5m
Load group	Average operating period per day (h)					
Ligh k < 0.50	<2	2-4	4-8	8-16	>16	
Medium 0.50 < k < 0.63	<1	1-2	2-4	4-8	8-16	>16
Heavy 0.30 < k < 0.80	<0.5	0.5-1	1-2	2-4	4-8	8-16
Very Heavy 0.80 < k < 1.00	<0.25	<0.5	0.5-1	1-2	2-4	4-8

AIMING TO BETTER TECHNOLOGY & CUSTOMER SAFETY

Domestic & Foreign periods based on accumulated technology and heavy industry and construction, committed to playing a leading role in the material handling field

Explanation of Hoist Designation

SC	T	S	1000	D	SP
SGCRANES Chain hoist	Traversing method O Ordinary type T Motor driven trolley L Low head type	Hoisting speed S Single Speed D Dual speed	Hoist capacity (kg) 1000kg 2000kg...	Num of Chain No Mark 1 fall D Several falls	Other SP Single Phase IV inverter EV Event

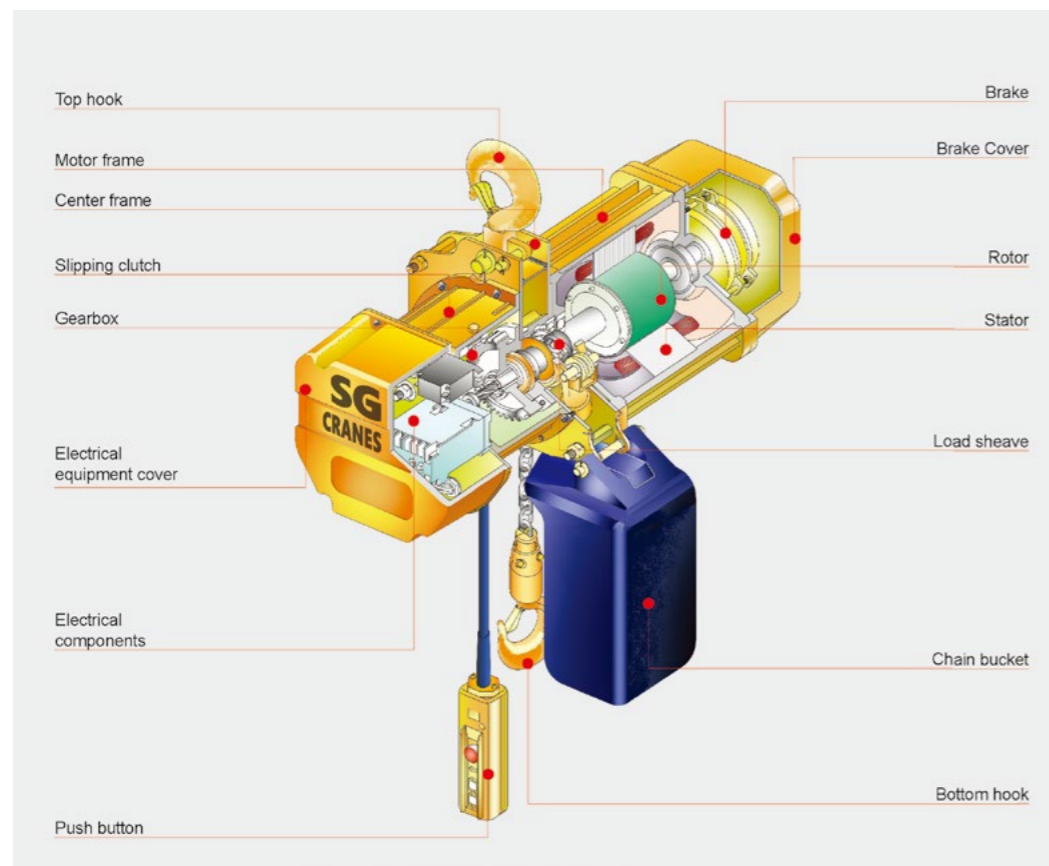

Suspension Type

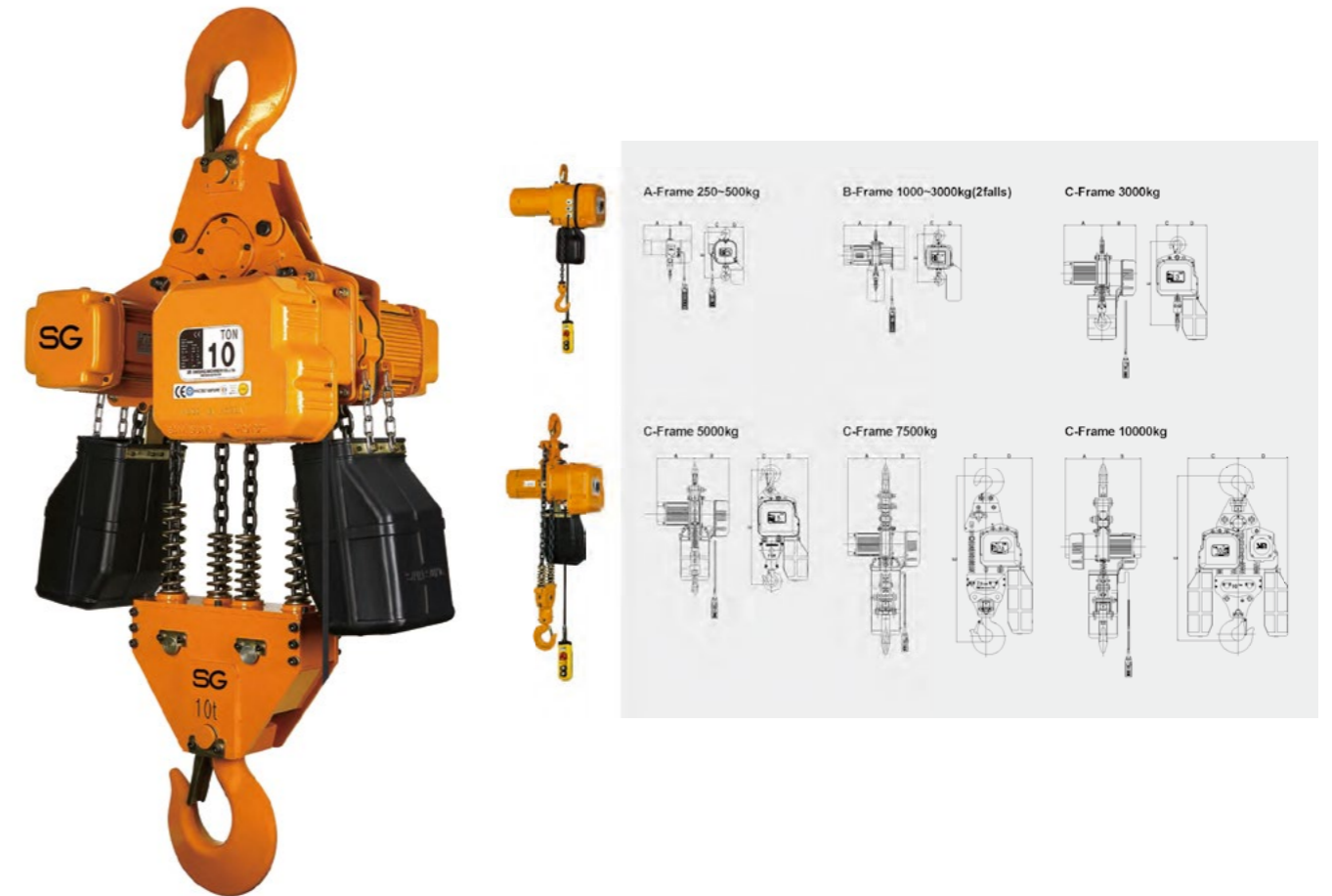

Table

Frame Model	Capacity (kg)	Hoisting Motor [single]				Hoisting Motor [Dual]				Load Chain (mm x Falls)	Net Weight (kg)	Dimension						
		Power (kw)		Speed(m/min)		Power (kw)		Speed (m/min)				Single			Dual			
		50Hz	60Hz	50Hz	60Hz	50Hz	60Hz	50Hz	60Hz			A	B	C	D	E	A	
A	SCO-S(D)250	0.42 x 4P	0.5 x 4P	4.6	5.6	0.42/0.21 x 4/8P	0.5/0.25 x 4/8P	4.7/2.4	5.6/2.8	ø5.0x1	36	240	196	157	165	410	257	
		0.42 x 4P	0.5 x 4P	7.0	8.4	0.42/0.21 x 4/8P	0.5/0.25 x 4/8P	7.0/3.5	8.4/4.2	ø5.0x1	36	240	196	157	165	410	257	
A	SCO-S(D)500	0.54 x 4P	0.65 x 4P	4.6	5.6	0.58/0.19 x 4/12P	0.7/0.23 x 4/12P	4.7/1.6	5.6/1.9	ø5.0x1	38	240	196	157	165	410	265	
		0.92 x 4P	1.1 x 4P	7.0	8.4	-	-	-	-	ø5.0x1	38	257	196	157	165	410	-	
B	SCO-S(D)1000	1.25 x 4P	1.5 x 4P	5.8	7.0	1.25/0.63 x 4/8P	1.5/0.75 x 4/8P	5.8/2.9	7.0/3.5	ø7.1x1	60	295	245	139	210	440	335	
	SCO-S(D)1250	1.7 x 4P	2.0 x 4P	5.8	7.0	1.25/0.63 x 4/8P	1.5/0.75 x 4/8P	5.8/2.9	7.0/3.5	ø7.1x1	60	295	245	139	210	440	335	
	SCO-S(D)1500	2.1 x 4P	2.5 x 4P	6.7	8.0	2.1/1.05 x 4/8P	2.5/1.25 x 4/8P	6.7/3.4	8.0/4.0	ø8.0x1	65	295	245	141	216	490	335	
	SCO-S(D)1800D	1.25 x 4P	1.5 x 4P	2.9	3.5	1.25/0.63 x 4/8P	1.5/0.75 x 4/8P	2.9/1.5	3.5/1.8	ø7.1x2	68	295	245	106	245	552	335	
	SCO-S(D)2000D	1.25 x 4P	1.5 x 4P	2.9	3.5	1.25/0.63 x 4/8P	1.5/0.75 x 4/8P	2.9/1.5	3.5/1.8	ø7.1x2	68	295	245	106	245	552	335	
	SCO-S(D)2500D	1.7 x 4P	2.0 x 4P	2.9	3.5	1.25/0.63 x 4/8P	1.5/0.75 x 4/8P	2.9/1.5	3.5/1.8	ø7.1x2	68	295	245	106	245	552	335	
	SCO-S(D)3000D	2.1 x 4P	2.5 x 4P	3.4	4.0	2.1/1.05 x 4/8P	2.5/1.25 x 4/8P	3.4/1.7	4.0/2.0	ø8.0x2	72	295	245	100	261	660	335	
C	SCO-S(D)2000	2.9 x 4P	3.5 x 4P	6.8	8.2	2.9/1.5 x 4/8P	3.5/1.75 x 4/8P	6.8/3.4	8.2/4.1	ø11.2x1	110	348	313	189	271	770	388	
	SCO-S(D)3000	3.000	3.5 x 4P	5.0	6.0	2.9/1.5 x 4/8P	3.5/1.75 x 4/8P	5.0/2.5	6.0/3.0	ø11.2x1	110	348	313	189	271	690	388	
	SCO-S(D)5000D	5.000	2.9 x 4P	2.5	3.0	2.9/1.5 x 4/8P	3.5/1.75 x 4/8P	2.5/1.3	3.0/1.5	ø11.2x2	126	348	313	115	346	980	388	
	SCO-S(D)7500D	7.500	2.9 x 4P	3.5 x 4P	1.7	2.0	2.9/1.5 x 4/8P	3.5/1.75 x 4/8P	1.7/0.8	2.0/1.0	ø11.2x3	318	385	325	190	430	1440	390
	SCO-S(D)10000D	10000	2.9 x 4P	3.5 x 4P	2.5	3.0	2.9/1.5 x 4/8P	3.5/1.75 x 4/8P	2.5/1.3	3.0/1.5	ø11.2x4	424	385	385	465	465	1440	390



## Motor Trolley Type

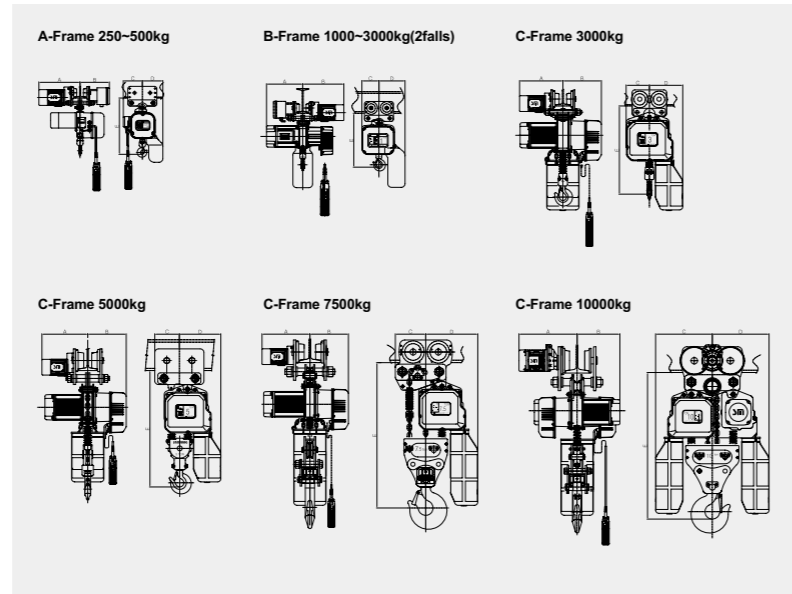

Table

Frame Model	Capacity (kg)	Hoisting Motor [single]				Hoisting Motor [Dual]				Traversing Motor				Load Chain (mm x Falls)	Net Weight (kg)	I-Beam Width (mm)	Min. Radius For Curve (mm)	Dimension															
		Power (kw)		Speed (m/min)		Power (kw)		Speed (m/min)		Power(kw) x Pole		Speed(m/min)						Single					Dual										
		50Hz	60Hz	50Hz	60Hz	50Hz	60Hz	50Hz	60Hz	50Hz	60Hz	50Hz	60Hz					A	B	C	D	E	A	B	C	D	E						
A	SCT-S(D)250	250	0.42 x 4P	0.5 x 4P	4.7	5.6	0.42/0.21 x 4/8P	0.5/0.25 x 4/8P	4.7/2.4	5.6/2.8	0.33 x 4P (0.22 x 6P) [0.17 x 8P]	0.4 x 4P (0.27 x 6P) [0.2 x 8P]	16.7 (11.1) [8.3]	200 (13.3) [10.0]	ø5.0 x 1	62	75-125	1200	335	238	130	193	444	355									
		0.42 x 4P	0.5 x 4P	7.0	8.4	0.42/0.21 x 4/8P	0.5/0.25 x 4/8P	7.0/3.5	8.4/4.2	ø5.0 x 1					62	75-125	1200	335	238	130	193	444	355										
		0.54 x 4P	0.65 x 4P	4.7	5.6	0.42/0.21 x 4/8P	0.5/0.17 x 4/8P	4.7/2.4	5.6/2.8	ø5.0 x 1					64	75-125	1200	335	238	130	193	444	355										
B	SCT-S(D)490	490	0.54 x 4P	0.65 x 4P	4.7	5.6	0.42/0.21 x 4/8P	0.5/0.17 x 4/8P	4.7/2.4	5.6/2.8	0.33 x 4P (0.22 x 6P) [0.17 x 8P]	0.4 x 4P (0.27 x 6P) [0.2 x 8P]	16.7 (11.1) [8.3]	200 (13.3) [10.0]	ø5.0 x 1	64	75-125	1200	335	238	130	193	444	355									
		0.54 x 4P	0.65 x 4P	4.7	5.6	0.63/0.21 x 4/12p	0.75/0.23 x 4/12p	4.7/1.6	5.6/1.9	ø5.0 x 1					64	75-125	1200	335	238	130	193	444	355										
		0.92 x 4P	1.1 x 4P	7.0	8.4	-	-	-	-	ø5.0 x 1					64	75-125	1200	335	238	130	193	452	355										
C	SCT-S(D)1000	1000	1.25 x 4P	1.5 x 4P	5.8	7.0	1.25/0.63 x 4/8P	1.5/0.75 x 4/8P	5.8/2.9	7.0/3.5	0.33 x 4P (0.22 x 6P) [0.17 x 8P]	0.4 x 4P (0.27 x 6P) [0.2 x 8P]	15.8 (10.0) [7.9]	190 (12.0) [9.5]	ø7.1 x 1	82	75-125	1200	295	335	139	212	440	335									
		1250	1.7 x 4P	2.0 x 4P	5.8	7.0	1.25/0.63 x 4/8P	1.5/0.75 x 4/8P	5.8/2.9	7.0/3.5					ø7.1 x 1	82	75-125	1200	295	335	139	212	440	335									
	1500	2.1 x 4P	2.5 x 4P	6.7	8.0	2.1/1.25 x 4/8P	2.5/1.25 x 4/8P	6.7/3.4	8.0/4.0	ø8.1 x 1					90	100-150	1500	295	365	140	213	460	335										
	1800	1.25 x 4P	1.5 x 4P	2.9	3.5	1.25/0.63 x 4/8P	1.5/0.75 x 4/8P	2.9/1.5	3.5/1.8	ø7.1 x 2					102	100-150	1500	295	365	140	245	530	335										
	2000	1.25 x 4P	1.5 x 4P	2.9	3.5	1.25/0.63 x 4/8P	1.5/0.75 x 4/8P	2.9/1.5	3.5/1.8	ø7.1 x 2					102	100-150	1500	295	365	140	245	530	335										
	3000	2.1 x 4P	2.5 x 4P	3.4	4.0	2.1/1.25 x 4/8P	2.5/1.25 x 4/8P	3.4/1.7	4.0/2.0	ø8.0 x 2					115	100-150	1500	295	365	140	308	610	335										
C	SCT-S(D)2000	2000	2.9 x 4P	3.5 x 4P	6.8	8.2	2.9/1.5 x 4/8P	3.5/1.75 x 4/8P	6.8/3.4	8.2/4.1	0.33 x 4P (0.22 x 6P) [0.17 x 8P]	0.4 x 4P (0.27 x 6P) [0.2 x 8P]	13.3 (8.3) [6.7]	160 (10.0) [8.0]	ø11.2 x 1	135	100-150	1500	353	313	190	271	650	386									
		3000	2.9 x 4P	3.5 x 4P	5.0	6.0	2.9/1.5 x 4/8P	3.5/1.75 x 4/8P	5.0/2.5	6.0/3.0					ø11.2 x 1	135	100-150	1500	353	313	190	271	650	386									
	5000	2.9 x 4P	3.5 x 4P	2.5	3.0	2.9/1.5 x 4/8P	3.5/1.75 x 4/8P	2.5/1.3	3.0/1.5	ø11.2 x 2					194	125-175	2000	370	313	200	337	880	405										
	7500	2.9 x 4P	3.5 x 4P	1.7	2.0	2.9/1.5 x 4/8P	3.5/1.75 x 4/8P	1.7/0.8	2.0/1.0	ø11.2 x 3					384	125-175	2000	465	330	260	430	1150	-										
SCT-S(D)10000D	10000	2.9 x 4P	3.5 x 4P	2.5	3.0	2.9/1.5 x 4/8P	3.5/1.75 x 4/8P	2.5/1.3	3.0/1.5	1.25 x 4P	1.5 x 4P	12.5	15	ø11.2 x 4	524	125-175	2000	465	390	465	465	1120	-										

## Single Phase Type

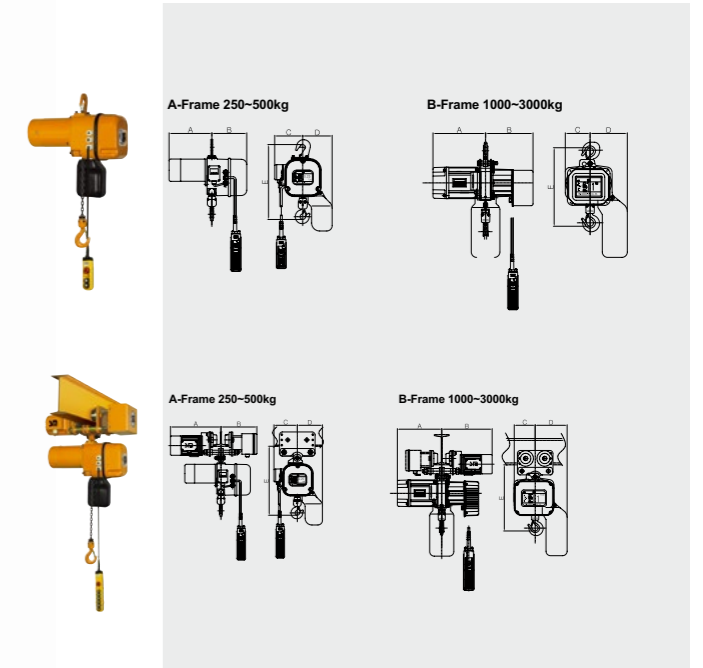

Table

Frame Model	Capacity (kg)	Hoisting Motor [single]				Load Chain (mm x Falls)	Net Weight (kg)	Dimension					
		Power (kw)		Speed (m/min)				Single					
		50Hz	60Hz	50Hz	60Hz			A	B	C	D	E	
A	SCO-S250-SP	250	0.42 x 4P	0.5 x 4P	4.6	5.6	ø5.0 x 1	36	240	196	157	165	410
		0.42 x 4P	0.5 x 4P	7.0	8.4	ø5.0 x 1	36	240	196	157	165	410	
		0.54 x 4P	0.65 x 4P	4.6	5.6	ø5.0 x 1	38	240	196	157	165	410	
B	SCO-S(D)490	490	0.54 x 4P	0.65 x 4P	4.6	5.6	ø5.0 x 1	38	240	196	157	165	410
		0.54 x 4P	0.65 x 4P	4.6	5.6	ø5.0 x 1	38	240	196	157	165	410	
		0.92 x 4P	1.1 x 4P	7.0	8.4	ø5.0 x 1	38	257	196	157	165	410	
B	SCO-S(D)1000	1000	1.25 x 4P	1.5 x 4P	5.8	7.0	ø7.1 x 1	60	295	245	139	210	440
		1800	1.25 x 4P	1.5 x 4P	2.9	3.5	ø7.1 x 2	68	295	245	106	245	552
		2000	1.25 x 4P	1.5 x 4P	2.9	3.5	ø7.1 x 2	68	295	245	106	245	552

Table

Frame Model	Capacity (kg)	Hoisting Motor [single]				Traversing Motor				Load Chain (mm x Falls)	Net Weight (kg)	I-Beam Width (mm)	Min. Radius For Curve (mm)	Dimension					
		Power (kw)		Speed (m/min)		Power(kw) x Pole		Speed(m/min)						Single					
		50Hz	60Hz	50Hz	60Hz	50Hz	60Hz	50Hz	60Hz					A	B	C	D	E	
A	SCT-S(D)250	250	0.42 x 4P	0.54 x 4P	4.6	5.6	0.33 x 4P	0.4 x 4P	16.7	200	ø5.0 x 1	62	75-125	1200	335	238	130	193	444
		0.42 x 4P	0.54 x 4P	7.0	8.4	0.33 x 4P	0.4 x 4P	16.7	200	ø5.0 x 1	62	75-125	1200	335	238	130	193	444	
		0.54 x 4P	0.65 x 4P	4.6	5.6	0.33 x 4P	0.4 x 4P	16.7	200	ø5.0 x 1	64	75-125	1200	335	238	130	193	444	
B	SCT-S(D)490	490	0.54 x 4P	0.65 x 4P	4.6	5.6	0.33 x 4P	0.4 x 4P	16.7	200	ø5.0 x 1	64	75-125	1200	335	238	130	193	444
		0.54 x 4P	0.65 x 4P	4.6	5.6	0.33 x 4P	0.4 x 4P	16.7	200	ø5.0 x 1	64	75-125	1200	335	238	130	193	444	
		0.92 x 4P	1.1 x 4P	7.0	8.4	0.33 x 4P	0.4 x 4P	16.7	200	ø5.0 x 1	64	75-125	1200	335	238	130	193	452	
B	SCT-S(D)1000	1000	1.25 x 4P	1.5 x 4P	5.8	7.0	0.33 x 4P	0.4 x 4P	16.7	200	ø7.1 x 1	82	75-125	1200	295	335	139	212	440
		1800	1.25 x 4P	1.5 x 4P	2.9	3.5	0.33 x 4P	0.4 x 4P	15.8	190	ø7.1 x 2	102	100-150	1500	296	365	140	245	530
		2000	1.25 x 4P	1.5 x 4P	2.9	3.5	0.33 x 4P	0.4 x 4P	15.8	190	ø7.1 x 2	102	100-150	1500	297	365	140	245	530



## Inverter Type

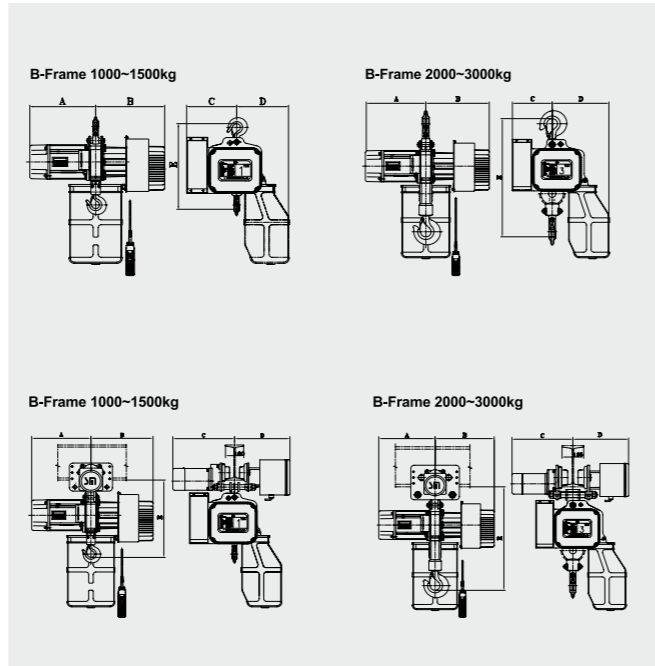

Table

Frame Model	Capacity (kg)	Hoisting Motor [single]				Load Chain (mm x Falls)	Net Weight (kg)	Dimension Single				
		Power (kw)		Speed (m/min)				A	B	C	D	E
		50Hz	60Hz	50Hz	60Hz							
SCO-1000-IV	1000	1.25 x 4P	1.5 x 4P	1.2 ~ 5.8	1.5 ~ 7.0	ø71 x 1	68	295	345	347	250	440
SCO-1250-IV	1250	1.7 x 4P	2.0 x 4P	1.2 ~ 5.8	1.5 ~ 7.0	ø71 x 1	68	295	345	347	250	440
SCO-1500-IV	1500	2.1 x 4P	2.5 x 4P	1.6 ~ 6.7	2.0 ~ 8.0	ø8.0 x 1	78	325	345	215	261	490
SCO-1800D-IV	1800	1.25 x 4P	1.5 x 4P	0.6 ~ 2.9	0.7 ~ 3.5	ø71 x 2	85	295	345	260	291	552
SCO-2000D-IV	2000	1.25 x 4P	1.5 x 4P	0.6 ~ 2.9	0.7 ~ 3.5	ø71 x 2	85	295	345	260	291	552
SCO-2500D-IV	2500	1.7 x 4P	2.0 x 4P	0.6 ~ 2.9	0.7 ~ 3.5	ø71 x 2	85	295	345	347	291	552
SCO-3000D-IV	3000	2.1 x 4P	2.5 x 4P	0.8 ~ 3.3	1.0 ~ 4.0	ø8.0 x 2	88	325	345	215	306	660

Table

Frame Model	Capacity (kg)	Hoisting Motor [single]				Traversing Motor				Load Chain (mm x Falls)	Net Weight (kg)	I-Beam Width (mm)	Min. Radius For Curve (mm)	Dimension Single				
		Power (kw)		Speed (m/min)		Power(kw) x Pole		Speed(m/min)						A	B	C	D	E
		50Hz	60Hz	50Hz	60Hz	50Hz	60Hz	50Hz	60Hz									
SCT-1000-IV	1000	1.25 x 4P	1.5 x 4P	1.2 ~ 5.8	1.5 ~ 7.0	0.33 x 4P	0.4 x 4P	3 ~ 16.7	4 ~ 20	ø71 x 1	89	75 ~ 125	1200	295	316	340	304	440
SCT-1250-IV	1250	1.7 x 4P	2.0 x 4P	1.2 ~ 5.8	1.5 ~ 7.0	0.33 x 4P	0.4 x 4P	3 ~ 16.7	4 ~ 20	ø71 x 1	89	75 ~ 125	1200	295	316	340	304	440
SCT-1500-IV	1500	2.1 x 4P	2.5 x 4P	1.6 ~ 6.7	2.0 ~ 8.0	0.33 x 4P	0.4 x 4P	3 ~ 15	3.5 ~ 18	ø8.0 x 1	97	100 ~ 150	1500	325	321	351	231	460
SCT-1800D-IV	1800	1.25 x 4P	1.5 x 4P	0.6 ~ 2.9	0.7 ~ 3.5	0.33 x 4P	0.4 x 4P	3 ~ 15	3.5 ~ 18	ø71 x 2	109	100 ~ 150	1500	295	321	351	231	530
SCT-2000D-IV	2000	1.25 x 4P	1.5 x 4P	0.6 ~ 2.9	0.7 ~ 3.5	0.33 x 4P	0.4 x 4P	3 ~ 15	3.5 ~ 18	ø71 x 2	109	100 ~ 150	1500	295	321	351	231	530
SCT-2500D-IV	2500	1.7 x 4P	2.0 x 4P	0.6 ~ 2.9	0.7 ~ 3.5	0.33 x 4P	0.4 x 4P	3 ~ 15	3.5 ~ 18	ø71 x 2	109	100 ~ 150	1500	295	321	351	231	530
SCT-3000D-IV	3000	2.1 x 4P	2.5 x 4P	0.8 ~ 3.3	1.0 ~ 4.0	0.33 x 4P	0.4 x 4P	3 ~ 15	3.5 ~ 18	ø8.0 x 2	112	100 ~ 150	1500	325	321	351	231	610

## Low Head Room Type

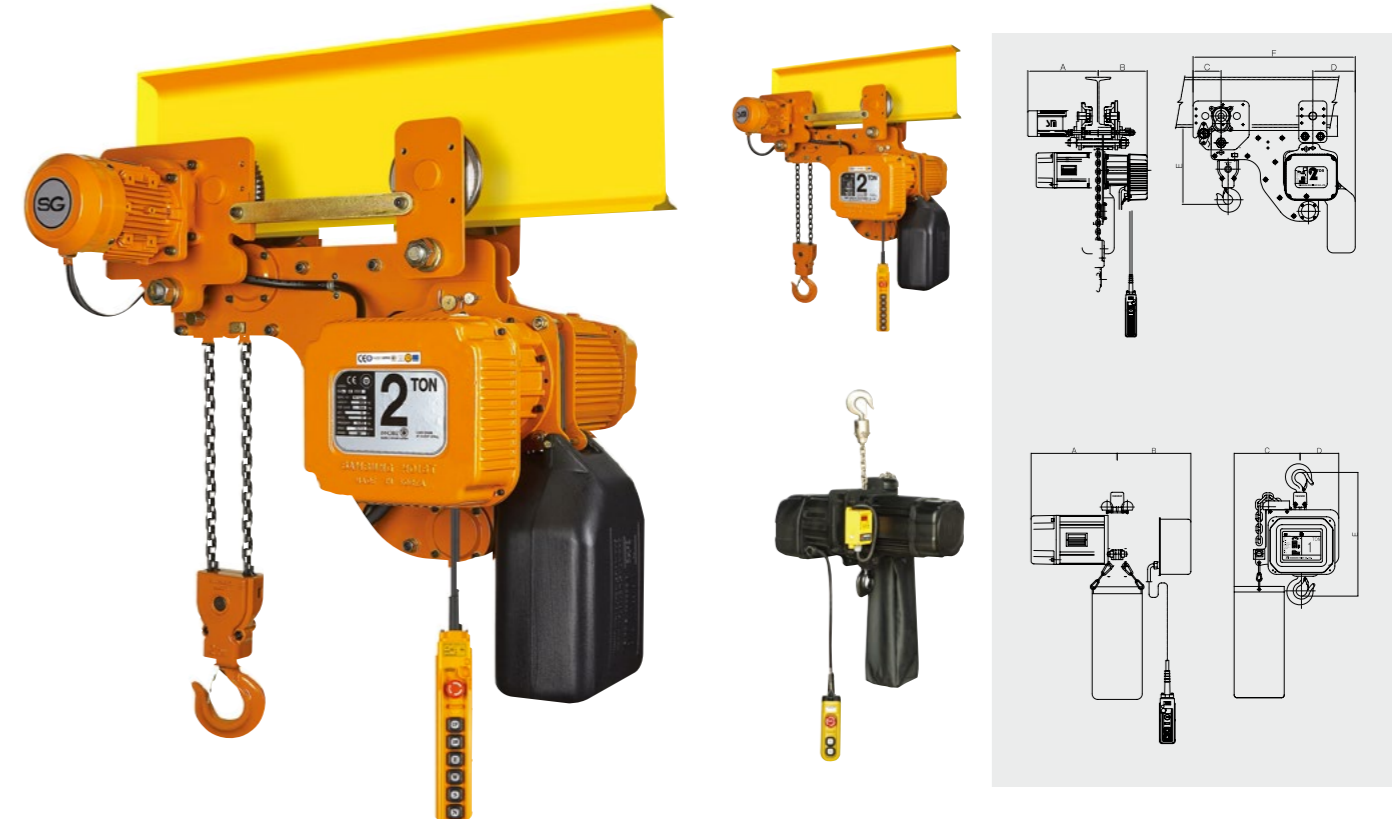

### Low Head Type

Frame Model	Capacity (kg)	Hoisting Motor [single]				Hoisting Motor [Dual]				Traversing Motor				Load Chain (mm x Falls)	Net Weight (kg)	I-Beam Width (mm)	Min. Radius For Curve (mm)	Dimension						
		Power (kw)		Speed (m/min)		Power (kw)		Speed (m/min)		Power(kw) x Pole		Speed(m/min)						Single			Dual			
		50Hz	60Hz	50Hz	60Hz	50Hz	60Hz	50Hz	60Hz	50Hz	60Hz	50Hz	60Hz					A	B	C	D	E	A	
SML-S(D)1000	1000	1.25 x 4P	1.5 x 4P	5.8	7.0	1.25/0.63 x 4/8P	1.5/0.75 x 4/8P	5.8/2.9	7.0/3.5	0.33 x 4P (0.22 x 6P)	0.4 x 4P (0.27 x 6P)	16.7 (11.1)	20.0 (13.3)	ø71 x 1	90	75 ~ 125	∞	335	245	132	212	320	802	350
SML-S(D)1250	1250	1.7 x 4P	2.0 x 4P	5.8	7.0	1.25/0.63 x 4/8P	1.5/0.75 x 4/8P	5.8/2.9	7.0/3.5	0.33 x 4P (0.22 x 6P)	0.4 x 4P (0.27 x 6P)	16.7 (11.1)	20.0 (13.3)	ø71 x 1	90	75 ~ 125	∞	335	245	132	212	320	802	350
SML-S(D)1500	1500	2.1 x 4P	2.5 x 4P	6.7	8.0	2.1/1.25 x 4/8P	2.5/1.25 x 4/8P	6.7/3.4	8.0/4.0	0.33 x 4P (0.22 x 6P)	0.4 x 4P (0.27 x 6P)	15.8 (10.0)	19.0 (12.0)	ø81 x 1	99	100 ~ 150	∞	350	245	140	216	390	820	350
SML-S(D)1800D	1800	1.25 x 4P	1.5 x 4P	2.9	3.5	1.25/0.63 x 4/8P	1.5/0.75 x 4/8P	2.9/1.5	3.5/1.8	0.33 x 4P (0.22 x 6P)	0.4 x 4P (0.27 x 6P)	15.8 (10.0)	19.0 (12.0)	ø71 x 2	112	100 ~ 150	∞	350	245	140	212	385	810	350
SML-S(D)2000D	2000	1.25 x 4P	1.5 x 4P	2.9	3.5	1.25/0.63 x 4/8P	1.5/0.75 x 4/8P	2.9/1.5	3.5/1.8	0.33 x 4P (0.22 x 6P)	0.4 x 4P (0.27 x 6P)	15.8 (10.0)	19.0 (12.0)	ø71 x 2	112	100 ~ 150	∞	350	245	140	212	385	810	350
SML-S(D)2500D	2500	1.7 x 4P	2.0 x 4P	2.9	3.5	1.25/0.63 x 4/8P	1.5/0.75 x 4/8P	2.9/1.5	3.5/1.8	0.33 x 4P (0.22 x 6P)	0.4 x 4P (0.27 x 6P)	15.8 (10.0)	19.0 (12.0)	ø71 x 2	112	100 ~ 150	∞	350	245	140	212	385	810	350
SML-S(D)3000D	3000	2.1 x 4P	2.5 x 4P	3.4	4.0	2.1/1.25 x 4/8P	2.5/1.25 x 4/8P	3.4/1.7	4.0/2.0	0.33 x 4P (0.22 x 6P)	0.4 x 4P (0.27 x 6P)	15.8 (10.0)	19.0 (12.0)	ø8.0 x 2	126	100 ~ 150	∞	350	245	140	216	490	820	350
SML-S(D)2000	2000	2.9 x 4P	3.5 x 4P	6.8	8.2	2.9/1.5 x 4/8P	3.5/1.75 x 4/8P	6.8/3.4	8.2/4.1	0.33 x 4P (0.22 x 6P)	0.4 x 4P (0.27 x 6P)	13.3 (8.3)	16.0 (10.0)	ø11.2 x 1	148	100 ~ 150	∞	364	313	140	272	510	890	390
SML-S(D)3000	3000	2.9 x 4P	3.5 x 4P	5.0	6.0	2.9/1.5 x 4/8P	3.5/1.75 x 4/8P	5.0/2.5	6.0/3.0	0.33 x 4P (0.22 x 6P)	0.4 x 4P (0.27 x 6P)	13.3 (8.3)	16.0 (10.0)	ø11.2 x 1	148	100 ~ 150	∞	364	313	140	272	510	890	390
SML-S(D)5000D	5000	2.9 x 4P	3.5 x 4P	2.5	3.0	2.9/1.5 x 4/8P	3.5/1.75 x 4/8P	2.5/1.3	3.0/1.5	0.33 x 4P (0.22 x 6P)	0.4 x 4P (0.27 x 6P)	13.3 (8.3)	16.0 (10.0)	ø11.2 x 2	213	125 ~ 175	∞	370	313	180	272	700	1010	390

### Event Type

Frame Model	Capacity (kg)	Hoisting Motor [single]				Load Chain (mm x Falls)	Net Weight (kg)	Dimension Single				
		Power (kw)		Speed (m/min)				A	B	C	D	E
		50Hz	60Hz	50Hz	60Hz							
SCO-500-EV	500	1.25 x 4P	1.5 x 4P	9.0	10.8	ø71 x 1	60	60	245	285	140	445
SCO-1000-EV	1000	1.25 x 4P	1.5 x 4P	5.8	7.0	ø71 x 1	60	60	245	285	140	445
SCO-1500-EV	1500	2.1 x 4P	2.5 x 4P	6.7	8.0	ø8.0 x 1	65	65	245	295	140	540

### Special Type



HIGH LIFTING TYPE    EXPLOSION PROOF    DOBLE GIRDER TYPE

- Superior operational efficiency and durability at high temperature, humidity and moisture.
- Free speed control, low noise level and vibration.
- Explosion proof at hazardous atmospheres.
- Lowering by gravity when brake system fails.
- Durable drum brake for safety breaking.
- Compact design : light weight and portable.



▲ Air Motor Trolley

## Air Hoist Compact Design

### Vane Type



▲ KA1S Series



▲ KA2S Series



▲ KA3S Series

### Gear Type



▲ KA4GS Series



▲ KA5GS Series

### Piston Type



▲ KA5S Series

## (Vane Type 0.25Ton ~ 30Ton)

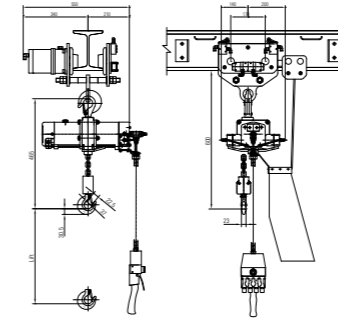

KM1M-025, 050(100)

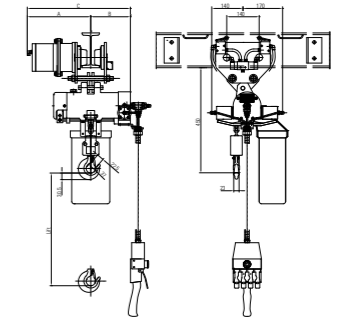

KM2M-100(200)

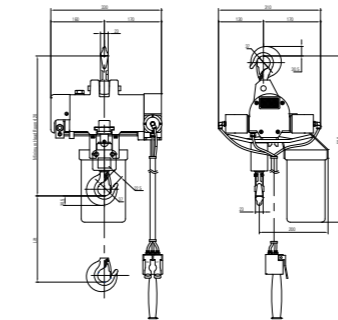

KA15-025, 050(100)

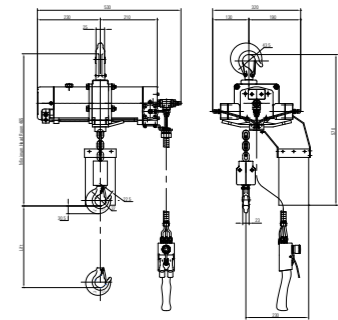

KA25-100(200)

### Specifications [KA 1&KA 2 Series]

Model	Capacity (kg)	Lifting Speed (m/min)				Lift(m)	Air Pressure (kgf/cm <sup>2</sup> )	Air Consumption (N-cm <sup>3</sup> /min)	Weight (kg)	Trolley Speed	Hose Dia(φ)
		No Load		Rated Load							
		Up	Down	Up	Down						
KA1S-025 KA1M-025	250	17	13	10	19	3	6	1.4	23	10-25	φ12/L=Less than 10m φ20/L=Less 10-20m
KA1S-050 KA1M-050	500	17	15	7.5	24	3	6	1.4	23	10-25	
KA1S-100 KA1M-100	1000	8.5	6.5	3.5	12	3	6	1.4	33	10-25	
KA2S-100 KA2M-100	1000	9	7	5	9	3	6	1.8	40	10-20	φ12/L=Less than 10m φ20/L=Less 10-20m
KA2S-200 KA2M-200	2000	4.5	3.5	2.3	5.5	3	6	1.8	45	10-20	

### Specifications [KA3 Series]

Model	Capacity (kg)	Lifting Speed (m/min)	Lift(m)	Air Pressure (kgf/cm <sup>2</sup> )	Air Consumption (N-cm <sup>3</sup> /min)	Chain Size	Weight (kg)	Trolley Speed	Hose Dia(φ)
KA3S-300 KA3M-300	3000	2.4	3	6	3.14	11.2	75	5-12	φ19
							140		
KA3S-600 KA3M-600	6000	1.5	3	6	3.14	11.2	96	5-10	φ25
							200		
KA3S-1000 KA3M-1000	10000	0.8	3	6	3.14	11.2	117	5-11	φ25
							182		
KA3S-1500 KA3M-1500	15000	0.5	3	6	3.14	11.2	138	5-12	φ25
							203		
KA3S-3000 KA3M-3000	30000	0.3	3	6	3.14	11.2	150	5-13	φ25
							215		

### Trolley

	I-BEAM TYPE	KH-TRACK TYPE
Min Radius(mm)	1500-	KH-
Traveling Speed(m/min)	10-25	Manual
Size	100,125,150	KH-L,II,BT5
Application	0.5-6 ton	0.25-1ton



## (Gear Type 3Ton ~ 100Ton)

**- Heavy capacity and High lifting speed**

It is available to produce up to 100 ton with compact size, using of heavy capacity gear type air motor.

**- Durable, compact design and light weight**

It is suitable for moisture and dust circumstance as steel body for excellent durability

**- Application for explosive area**

It is possible for explosive area such as offshore plant, chemical plant, petrochemical plant and refinery plant instead of electrical hoist.

**- Enclosed disc brake**

It is easy for maintenance with self-adjustment of brake gap and excellent corrosion proof.

**- Free speed control**

It is available to control the speed by pendent switch.

**- Upper & Lower limit switch**

It is integrated with hoist body securely.

**- Emergency stop button**

It is installed on Push button switch to stop at emergency situation.

**- Overload protector (O.L.P)**



▲ KA4GS-0600

**Specifications [KA2GS & KA4GS Series]**

Model	Capacity (Tons)	Lifting Speed (m/min)	Fall	Air Pressure (kgf/cm <sup>2</sup> )	Air Consumptions (m <sup>3</sup> /min)	Chain Size (mm)	Weight (kg)
KA2GS-0300	3	1.9	1	6.3	3.5	11.2	80
KA4GS-0600	6	1.8	1	6.3	8	16	130
KA4GS-1200	12	0.9	2	6.3	8	16	180
KA4GS-1800	18	0.6	3	6.3	8	16	250
KA4GS-2500	25	0.4	4	6.3	8	16	330

**Specifications [KA5GS Series]**

Model	Capacity (Tons)	Lifting Speed (m/min)	Fall	Air Pressure (kgf/cm <sup>2</sup> )	Air Consumptions (m <sup>3</sup> /min)	Chain Size (mm)	Weight (kg)
KA5GS-1250	12.5	3	1	6.3	12.5	22	400
KA5GS-2500	25	1.4	2	6.3	12.5	22	550
KA5GS-3750	37.5	1	3	6.3	12.5	22	930
KA5GS-5000	50	0.6	4	6.3	12.5	22	1200
KA5GS-S075	75	0.4	3	6.3	12.5	32	1900
KA5GS-S100	100	0.3	4	6.3	12.5	32	2500

## (Piston Type 5Ton ~ 20Ton)

- Durability to maintenance, rigging and shipyard applications.

- High torque piston motor.

- Automatic, multi-disc oil bath motor brake.

- Compact planetary gearing.

- Pendent switch controlled.

- 5~20ton hoist in standard lie

- It is available to produce up to 80ton depending on the request.



▲ KA5S-P10



▲ Piston type Air Jib Crane

**Specifications [KA 1&KA 2 Series]**

Model	Capacity (kg)	Lifting Speed (m/min)	Fall	Air Pressure (kgf/cm <sup>2</sup> )	Air Consumption (N-cm <sup>3</sup> /min)	Weight (kg)	Trolley Speed (m/min)
KA5S-P05	5	2.7	1	6	4.2	170	6.1
KA5M-P05						300	
KA5S-P10	10	1.35	2	6	4.2	220	6.1
KA5M-P10						400	
KA5S-P15	15	0.9	3	6	4.2	348	6.1
KA5M-P15						578	
KA5S-P20	20	0.67	4	6	4.2	390	6.1
KA5M-P20						670	

- Offering both of hoisting and floating at the same time as well as no jumping phenomenon and adjustable precise positioning up to 400mm both for upward and downward.
- High speed of 1000mm/sec with adjustable speed by control valve
- Automatic self floating interlocked with braking and lower noise level
- Safety feature by overload limit device
- Additional check valve for interruption of air supply
- No lubrication is required.

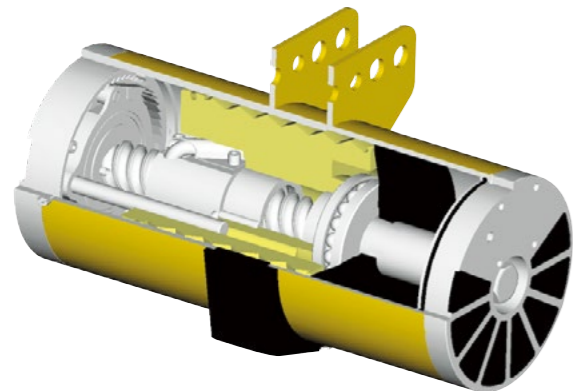

### Single Wire Rope Units (Air Pressure 7kgf/cm<sup>2</sup>)

Model	Capacity (Tons)		Lifting Speed (m/min)		Net Weight	
	kg	lbs	mm	in	kg	lbs
KAB-070-200	60	132	2000	79	23	51
KAB-100-300	100	220	3000	118	42.5	94
KAB-160-200	150	331	2000	79	40	88
KAB-230-200	220	485	2000	79	50	110

### Single Chain Units (Air Pressure 7kgf/cm<sup>2</sup>)

Model	Capacity (Tons)		Lifting Speed (m/min)		Net Weight	
	kg	lbs	mm	in	kg	lbs
KAB-C070-200	60	132	1700	70	26	51
KAB-C100-300	100	220	2700	106	46	102
KAB-C160-200	150	331	1700	70	43	95
KAB-C230-200	220	485	1700	70	53	117

- Automatic weight sensor
- Control by 5~10% force weight
- Fine control for precise work

### Specifications [Zero Balancer]

Model	KAB-070ZW KAB-100ZW KAB-160ZW	KAB-070ZG KAB-100ZG KAB-160ZG
Max, Load(kg)	60	600
	100	100
	150	150
Control System	Dual Control	Control by Grip
Net Weight(kg)	33	25
	53	45
	50	42



### Tandem Type

Model	Capacity (Tons)		Lifting Speed (m/min)		Net Weight	
	kg	lbs	mm	in	kg	lbs
KAB-T200-300	200	441	3000	118	92	203
KAB-T320-200	300	661	2000	79	90	198
KAB-T450-200	440	970	2000	79	110	243

### Reeved Type

Model	Capacity (Tons)		Lifting Speed (m/min)		Net Weight	
	kg	lbs	mm	in	kg	lbs
KAB-R200-150	200	441	1500	59	47	104
KAB-R320-100	300	661	1000	39	45	99
KAB-R450-100	440	970	1000	39	56	124

### Tandem Reeved Type

Model	Capacity (Tons)		Lifting Speed (m/min)		Net Weight	
	kg	lbs	mm	in	kg	lbs
KAB-TR400-150	400	882	1500	59	95	209
KAB-TR640-100	600	1323	1000	39	92	203
KAB-TR900-100	880	1940	1000	39	115	254



## (Air, Electric)

- Range of 250-20,000kg
- Able to use for explosion proof & dusty area (Spark Free)
- Excellent for high humidity area
- Easy to adjust speed precious locationing
- Most safety design



Model	Capacity (kg)	Air Motor (kw)	Air Consumption (N-l/min)	WireRope Dia (mm)	Winding Speed (m/min)	Net Weight (kg)	Remark
KAW-V025-07	250	1.7	2,200	6.3	25	120	
KAW-V050-07	500	3.5	3,500	8	30	250	
KAW-P100-25	1,000	6.1	7,800	11.2	25	350	
KAW-P200-20	2,000	10.6	11,900	16	20	450	
KAW-P300-20	3,000	16.0	19,700	20	20	500	
KAW-P500-20	5,000	23.0	25,300	25	20	650	

## Remote Control

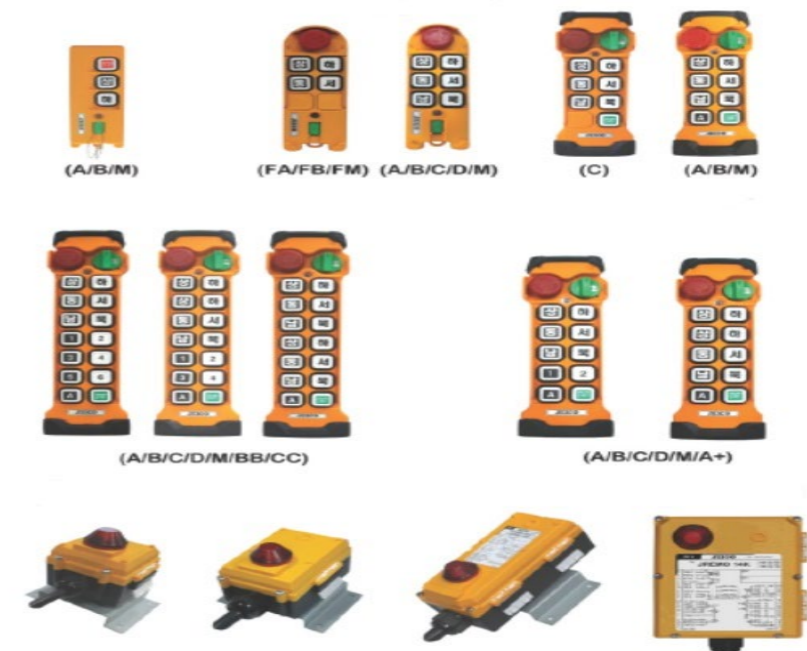

## Load Cell



## Controller

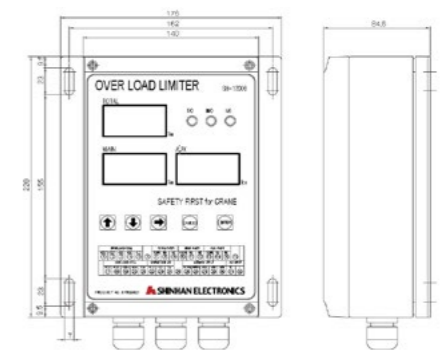

## Converter



## Lager Display











**SG Engineering co.**

Jungdong, Bless land 9F 908) 317, Gilju-ro , Bucheon-si, Gyeonggi-do , 14534 , Korea

**Tel** +82-32-325-1635 | **Fax** +82-32-325-1636

**Email** tiger1635@naver.com

sgkim@sgcranes.com

SGCRANES reserves the right to alter or amend the above information without notice. This document and the information contained herein, is the exclusive property of SGCRANES and represents a non-public, confidential and proprietary trade secret that may not be reproduced, disclosed to third parties, altered or otherwise employed in any manner whatsoever without the express written consent of SGCRANES.  
Copyright © (2018-5) SGCRANES, All rights reserved.

ver.# : SG201812